



Marketing Management

Elixir Marketing Mgmt. 64 (2013) 19311-19317

Elixir
ISSN: 2229-712X

Customer relational loyalty: proposal and validation of a measurement scale

Ali Hadj Khalifa^{1,*}, Basem Barqawi², Mohamed Mahjoub Dhiaf² and Moetaz Amayri²

¹Department of Management/ Higher Institute of Business Administration of Sfax-Route de l'Aérodrome Km 4, Sfax 3000- Tunisia.

²Department of Management/ Emirates College of Technology/Millennium Tower, Sheikh Hamdan Street, P. O. Box: 41009, Abu Dhabi, UAE.

ARTICLE INFO

Article history:

Received: 9 September 2013;

Received in revised form:

3 November 2013;

Accepted: 11 November 2013;

Keywords

Loyalty,
Relational Approach,
Critical Incidents,
Factorial Analysis,
Structural Model,
Banks.

ABSTRACT

Customer loyalty has become one of the key factors for strong company competitiveness. It has become a matter of concern, for both managers and researchers. Despite the relatively abundant literature on loyalty in Marketing, the notion of loyalty appears to be ambiguous. Our paper proposes a new conceptualization and an attempt to measure the concept of loyalty using a “relational approach”. It apprehends loyalty through customers’ responses towards “critical incidents” in the context of customer-bank relationships. In our research, we represent “critical incidents” by a “punctual dissatisfaction” and a “higher degree of competitiveness offered by competitors”. We use the Structural Equation Model to analyze the survey data given from 729 respondents from banks in Tunisia. The results have revealed five dimensions of customer loyalty: “tolerance of punctual dissatisfaction”, “resistance to competitors’ persuasion”, “integrative negotiation and claims”, “negative word of mouth”, and “opportunism”.

© 2013 Elixir All rights reserved

Introduction

Relationship marketing has become one of the key factors affecting company competitiveness (Chu and Shiu, 2009). The main concept that underlies relationship marketing is customer loyalty. Despite the multitude of researches on customer loyalty, this concept remains vague and needs more clarification (Dubois and Laurent, 1999). Researches on the concept of customer loyalty have been conducted using different approaches: a behavioural approach, an attitudinal approach and a mixed approach. The behavioural approach to customer loyalty is centred on the frequencies and proportions of purchase: a customer is loyal if he chooses the same brand at least three successive times (Jacoby and Chesnut, 1978). As for the attitudinal approach, it focuses on the predispositions, preferences, attitudes and intentions regarding repeated purchase (Jacoby and Kyner, 1973). Finally, the mixed approach combines behaviour and attitudes. It considers customer as loyal if his behaviour is stable and associated with a positive attitude toward the brand/product (Dufer and Moulins, 1989; Baldinger and Rubinson, 1996; Dick and Basu, 1994). While these approaches have helped clarifying the concept of customer loyalty, critics still emphasise the need for more clarification (Fournier, 1998; and Laurent Dubois, 1999; N'Goala, 2003; Aurier, Benavent and N'Goala, 2001). According to Dubois and Laurent (1999), “*Brand loyalty, although an old idea central to marketing practice, remains a poorly understood and measured construct*” (p. 657).

Given the limitations of attitudinal, behavioural and composite approaches largely developed in the marketing literature, contemporary research tends to point toward a relational approach of loyalty. Under this approach, customer loyalty is positioned to lead to a continuing relationship with provider or brand. It represents an expression of the emotional relationship that binds a consumer to a provider/brand and manifests itself in critical situations of purchase and

consumption. Moulins (1998) emphasises the dynamic character of loyalty by presenting it not as a rule, but rather as a relationship. In this way, loyalty is considered a relational development process in which the contributions of both partners strengthen mutual loyalty (Dwyer *et al.*, 1987; Evans and Laskin, 1994; Frisou, 1998). In other words, as time goes by, consumers will uphold the same attitude to buy a certain brand in a similar condition, and that means preference, satisfaction and willingness to repurchase a certain brand consistently (Chu and Shiu, 2009). Loyalty is not just an abstract concept. It can be translated into deeds and behaviour (N'Goala, 2003). As a result, it is manifested in behavioural and psychological dependence and creates a firm resolve to continue the relationship even in the presence of some critical incidents, which can be defined as a leading force in consumer to resist change of brands despite purchase situations and intended consumption (Oliver, 1997; Aurier *et al.*, 2001).

Approaches of loyalty: a review of the literature

The most common sense of loyalty was based on the behavioural dimension. In the area of public consumption, customer loyalty (to a product or a brand) is judged from his conduct of procurement and redemption upon the stock's renewal (Jacoby and Chesnut, 1978). In an exhaustive review, Jacoby and Chesnut (1978) identified 33 measures for operating brand loyalty based on the frequency of purchase or the proportions of purchase.

Despite its contributions, this approach has some drawbacks (Filser, 1994). First, the measures, based on the buying sequences, have a dichotomous nature: whether the consumer is loyal or not. In addition, it lacks the phenomenon of multi-loyalty which is very common in the area of large public consumption (Dufer and Moulins, 1989). Finally, forecasts based on stochastic models – implied in the approach – have only a limited reliability: The past is not the best way to predict future behaviour. In response to the limits of the behavioural

Tele:

E-mail addresses: ahadjkhalifa@yahoo.fr

© 2013 Elixir All rights reserved

approach, several authors (Day, 1969; Jacoby, 1971; Jacoby and Kyner, 1973) pointed out that brand loyalty could not be restricted to its behavioural dimension, and thus to a simple measure of purchase repetition. To qualify as a faithful repetitive buyer, we should also ensure that he develop, with respect to the brand, a suitable attitude in order to distinguish loyalty from other forms of purchasing. Within this attitudinal approach, the notion of loyalty has been construed as commitment to the brand in order to express better the intentional nature of the loyalty's conduct. Most measures of this commitment (Cunningham, 1967; Jacoby and Chesnut, 1978; Laurent and Kapferer, 1992) have a common thread, i.e. to question the consumer's buying behaviour in case of situational change of the tender (stock break in the usual shop, for example) which prevents him from buying his usual brand. (Stock break refers to temporary postponement of purchase, change in store to find the desired brand, or immediate rebranding; see Cunningham, 1967). However, such measures of the attitudinal approach's loyalty show some limits including the lack of actual purchase's behaviour measurement. The measures focus solely on the attitudinal behaviour and not the actual one. Yet the only measure of the intention of behaviour is not predictive of actual behaviour (Filser, 1994). Indeed, Dubois and Quaghebeur (1997) have shown, through a longitudinal study, the fragility of this type of measure from the comparison made between the declared intentions of loyalty and their actual behaviour.

Day (1969) is among the first to highlight the importance of a combined approach, i.e. attitudinal and behavioural, for a more accurate measure of brand loyalty. This approach shows that the estimated purchase made from a combination of behavioural measure of faithfulness and the attitude to the mark are twice as reliable as those made with a pure stochastic model. Jacoby (1975), extending the work of Day (1969), identified three conditions to qualify a buyer's loyalty to one brand: (1) actual purchase behaviour; (2) repetition over time; and (3) accompaniment of a positive attitude toward the brand. More recently, Baldinger and Rubinson (1996) questioned the link between attitude and behaviour and confirmed the results through an extensive longitudinal study. The study shows that purchase expectation made from a position of attitudinal and behavioural loyalty is much more reliable.

To overcome the limitations of previous approaches, some authors (Olivier, 1997; Laurent and Dubois, 1999; Fournier, 1999; Aurier, and N'Goala Benavent, 2001; N'Goala, 2003) emphasize the importance of the study of concept of loyalty in a relational perspective. Defining loyalty in its entire relational dimension considers the intense link established between the customer and the provider/brand. According to Oliver (1997, p392), "*Loyalty is seen as a force that drives the consumer to resist change brand despite situations of purchase and consumption that meets*". It manifests itself in all its power in "situations of adversity", especially when expectations are overturned (punctual dissatisfaction), or when competition begins offensive actions (competitor's persuasion) (Laurent and Dubois, 1999). For the latter, "*espoused loyalty in the face of a reason to change (e.g. a different purpose) would appear to be more informative about brand loyalty than is loyalty in the face of no particular reason*" (p. 658).

Measuring loyalty in the broad sense is to estimate the propensity of consumers to resist sustained actions to competitors' persuasion and possibly tolerate punctual dissatisfaction (Aurier et al., 2001). This is in line with the composite measure of loyalty. Day (1969) has already measured

loyalty by combining the purchase proportions to the attitudes toward the brand. In this spirit, customer loyalty has been operationalized by the degree of tolerance to a price increase (the maximum price accepted by the consumer before changing brand), the conduct in the case of stock break (temporary postponement of purchase or change in store to find the desired brand or rebranding immediately) (Cunningham, 1967) or the scope of the search for information before buying (Newman and Werbel, 1973). The constructed composite indices represent a better predictive validity than the mere attitude towards the brand and an upper validity compared to rebuying observed behaviour (Jacoby and Chesnut, 1978). However, these indices, generally applied to consumer products, are applicable only for specific purchase situations (price increase or out of stock). Aurier, Benavent and N'Goala (2001) have proposed to extend this approach by considering two frequent hypothetical situations: (1) the competitors' persuasion which is translated by a high-value offer from competitors at the time of purchase (quality/price) and (2) recurrent dissatisfaction that derives from a reversal of expectations in the consumer experience.

Bitner (1990) conceptualized loyalty through the concept of the "critical incident" defined as one that "significantly affects the stability of certain activities". Following a study in the services sector, Keaveney (1995) gave a range of triggers in the change of supplier, presented in the order of importance, and the most important thing is the gaps in the central services (core service failure). According to N'Goala (2003), the responses of consumers faced with a critical incident can be very different from the sudden break of the relationship, the "negative word of mouth", and through the use of negotiation. A critical incident may either be a more lucrative offer from the competition or a punctual dissatisfaction.

Hirschman (1970) discusses the concept of resistance of consumers to competitor's persuasion. According to him, the consumer will resist a competitor's persuasion if he thinks that the brand will take steps to improve its products and services. However, he considers only one form of consumer response to a competitor's persuasion (departure or continuity). Aaker (1996) assumes that a loyal consumer base represents a barrier to entry, a basis for a price premium, time to respond to competitor innovations, and a bulwark against deleterious price completion. Brand loyalty is a core dimension of brand equity.

As there are different styles of response to punctual dissatisfaction, there seems to be different modes of response to competitor's persuasion (N'Goala, 2003). Indeed, faced with "a reason to change" (punctual dissatisfaction or competitor's persuasion), the consumer must answer several key questions: (1) to change brands or continue the relationship despite the circumstances? (2) to choose between a resolution integration (cooperation) and a competitive problem resolution (conflict)? and (3) to act in a prejudicial manner to the brand or remain loyal to it? (See Table 1).

Table 1: A Typology of Consumer Responses

Facets	Response in case of punctual dissatisfaction	Response in the event of competitor's persuasion
Stability / Change	Tolerance for dissatisfaction	Resistance to competitors' persuasion
Cooperation / Conflict	Constructive Claim	Integrative Negotiation
Loyalty / Disloyalty	Negative "Word of Mouth"	Opportunism

Conceptual model and research assumptions

We are poised to ultimately adopt the approach that considers various manifestations of brand loyalty. Loyalty must

be understood through commitment in the relationship and durable propensity to behave in a favourable or unfavourable manner in the long term (attitude). We believe it is important to understand loyalty through the following six events developed by N'Goala (2003):

- (1) Sensitivity to competition, which means the customer's sensitivity in facing a more attractive offer from the competition;
- (2) "Tolerance to punctual dissatisfaction" which means the degree of customer's tolerance of timely dissatisfaction towards current brand;
- (3) The trend of opportunism, which means the operating behaviour of an opportunity offered by the competition despite the relationship with the current brand;
- (4) The propensity to claim, which means the claimed behaviour shown by the client to his current brand in case of punctual dissatisfaction;
- (5) The use of negative word of mouth, which means the transmission of negative information about the brand in case of punctual dissatisfaction; and
- (6) The trend of integrative bargaining, which means the customer's use of a constructive negotiation as a means of conflicts' resolution with his current brand.

This approach broadens the study of loyalty beyond the simple purchase of a product (intentional or observed). It is important to measure both the consumer's commitment and his attitude or propensity to behave in a consistent, cooperative and loyal manner towards the brand in critical situations. The notion of commitment, which is always clearly related to the issue of continuity or behaviour change, is generally equated with loyalty ("brand commitment", "commitment to the relationship") (Morgan and Hunt, 1994). Commitment can be defined as the desire to maintain a valued relationship (Moorman, Zaltman, Deshpande, 1992), as an implicit or explicit promise of continuity between the relational exchange between partners (Dwyer, Schurr and Oh, 1987, Frisou, 1996), or as a rooted belief among the partners that the importance of the relationship justifies their consented maximum effort to maintain it (Morgan and Hunt, 1994).

Frisou (1996) shows the central role of concept of commitment in the definition of a relational loyalty. The commitment to brand tends to cushion the frequent upheavals of the relationship (dissatisfaction over timely promotion of competition). For Scholl (1981, p589), commitment is defined as a "*force that maintains behavioural direction when expectancy/equity conditions are not met.*" It means a "*global, internal, subjective mediator of stay-leave decisions*" (Rusbult and Drigotas, 1992, p. 65). Similarly, Gurviez (1999) defines the commitment of consumers towards the brand as "the implicit or explicit intention to maintain a lasting relationship with the mark causing emotional attachment to the brand and having a positive impact on loyalty purchasing behaviour".

For Kim, Mourris and Swait (2008), brand commitment is one of the determinants of true loyalty. Indeed, customers will be more "truly" loyal to a brand when they have a higher level of commitment toward the brand. Ultimately, commitment means a constant desire to maintain a relationship of exchange despite the circumstantial situations. It plays a stabilizing role of attitudes (Frisou 1996). It guarantees the continuity of the relationship between a consumer and the brand despite the offers made by the competition and the occasional dissatisfaction that he may have (N'Goala, 2007).

In light of the above contributions, we propose the following research hypotheses:

H1: The consumer's commitment is negatively associated with susceptibility to competitor's persuasion:

H2: The consumer's commitment is positively related to trading integration;

H3: The consumer's commitment is negatively associated with opportunism;

H4: The consumer's commitment is positively associated with tolerance to punctual dissatisfaction;

H5: The consumer's commitment is positively related to the constructive claim; and

H6: The consumer's commitment is negatively related to the "negative word of mouth."

Methodology of Research

In order to test our hypotheses and develop valid and reliable measurement scales, we followed the traditional framework proposed by Churchill (1979), while integrating the comments and developments made in respect of this procedure and adapting the tools of statistical analysis (Cohen *et al.*, 1990).

The Choice of Ground

The context of our investigation is the Tunisian banking sector. We are studying the relationship between commercial banks and their customers. Our interest in this sector is supported by the trivialization of banking services and the increased competition (Zouari, 2006). This new deal makes customers' loyalty a strategic objective of any bank and one of the factors of competitiveness.

Measures Constructed

This phase was devoted to generate a set of items, both on the basis of existing scales (N'Goala, 2003) and from a series of interviews conducted with some banks' customers in different regions of Tunisia. Indeed, a qualitative study was conducted on the basis of semi-structured interviews. This qualitative study was seen as a preliminary step to the quantitative study (Appendix A). It helped to refine the boundaries of our conceptual area and ensure the adaptation of different items built and developed in our search context.

Data Collection

A preliminary data collection was carried out to ensure a proper understanding of items by respondents in order to purify the measures, if warranted. This pre-test was conducted among a sample of 60 customers selected by convenience and without verifying the condition of representativeness. Relying on the results of this pre-test phase, a second survey was administered on a sample of 1000 customers spread over 5 regions (Sfax, Sousse, Gafsa, Gabes and Tunis). The sampling method adopted was that of convenience. A final sample of 729 customers qualified as unit of analysis.

Results

The Measurement Model

We have subjected a number of dimensions of the survey data through principal components analysis using the rule of the value exceeding 1 and a contribution factor of at least 0.5 (Table 2) (Evrard *et al.*, 2003). We have carried out a rotation axis factor to increase the clarity of the solution (Varimax rotation). We then tested the reliability of resulting components to select the items that should be retained for further study.

The matrix of components after rotation (Table 3) shows that each item is associated with one and only one factor. In addition, the respective correlation coefficients are significant. However, we note that the items relating to "integrative negotiation" and those relating to "claim" form a single factor.

Table 2: Total Variance Explained

Component	Initial Eigen values			Extraction Sums of squares of factors selected			Sum of squares of factors retained for rotation	
	Total	% Variance	Cumulative%	Total	Total	% Variance	Cumulative%	
1	5.100	31.878	31.878	5.100	4.281	26.754	26.754	
2	4.263	26.644	58.522	4.263	2.884	18.026	44.780	
3	1.680	10.503	69.025	1.680	2.366	14.786	59.566	
4	1.290	8.065	77.090	1.290	1.976	12.352	71.917	
5	1.052	6.573	83.663	1.052	1.879	11.746	83.663	
6	.696	4.348	88.012					
7	.476	2.974	90.986					
8	.388	2.427	93.413					
9	.295	1.846	95.259					
10	.201	1.257	96.516					
11	.168	1.047	97.564					
12	.131	.821	98.384					
13	9.594E-02	.600	98.984					
14	7.092E-02	.443	99.427					
15	5.500E-02	.344	99.771					
16	3.666E-02	.229	100.000					

N of Items = 16
Alpha = .80

Table 3: Matrix Components after Rotation

	Components				
	1	2	3	4	5
TOL 2	.359	-.219	-.230	-.260	.766
TOL 3	.241	-7.257E-02	6.056E-02	-2.702E-02	.893
NEGO1	.905	-.139	-9.306E-02	.112	.136
NEGO 2	.876	-6.742E-02	-.130	-4.963E-02	.132
BORNEG1	.361	4.047E-02	.300	.591	.457
BORNEG 2	-7.315E-02	.278	.215	.719	-.327
BORNEG 3	.147	.269	-5.029E-02	.849	-5.694E-02
CLAIM1	.882	7.664E-03	.113	-1.005E-02	9.719E-02
CLAIM 2	.906	.104	1.006E-03	6.321E-02	.197
CLAIM 3	.861	-7.019E-02	5.962E-02	.143	.140
SAP1	-5.382E-03	.927	9.761E-02	.188	-8.520E-02
SAP 2	-8.356E-02	.901	.271	.151	-.142
SAP 3	-5.088E-02	.915	.223	.178	-2.909E-02
OPPORTU1	-1.693E-03	.133	.898	.147	-.156
OPPORTU 2	-1.893E-02	.280	.781	-.259	.143
OPPORTU 3	-8.775E-03	.189	.761	.322	-1.483E-02

These two constructs represent two sides of a single factor. Therefore, we propose to integrate them to the same axis called "claims and negotiation".

We evaluated the reliability of each dimension separately, by calculating the corresponding Cronbach alpha coefficients. All components that have reliability of less than 0.60 were excluded. We then performed a confirmatory factor analysis on all measures with LISREL (Jöreskog and Sörbom, 2001). The results of the exploratory factor and confirmatory analyses show that most scales of measurement used in this research retain their reliability.

The Structural Model

Given the large number of items, it seemed more appropriate to aggregate the concepts and estimate a structural model. The estimated model presents an acceptable adjustment (see Table 4). The value of RMSEA (0.07) is below the recommended threshold of 0.08. The all adjustment indices (see table 4) have values above the threshold chosen (0.9). Such results suggest that we should not reject the model because it has the advantage to predict satisfactorily the majority of variables. The convergent and discriminate validities are also checked for all variables measuring loyalty. Indeed, all indications of AVE are above 0.5. In addition, the index of AVE roots for each

variable remains above its correlation with all other variables, which leads us to conclude that the discriminator validity of the variables is verified. The indicator R^2 , reflecting the explained percentage of variance, presents the widely acceptable values for all the exogenous variables of the model. The proportion of variance (R^2) for each of the events of statistical confidence is high: "Punctual dissatisfaction tolerance" (0.65), "Opportunism" (0.66), "Sensitivity to competitors' persuasion" (0.57), "Word of mouth" (0.46), and "Integrative negotiation and claims" (0.49). These indices provide sufficient support to assume a link between the commitment and the different manifestations of loyalty.

The results help us to confirm the notion that consumer's sustainable emotional engagement constitutes one of his loyalty dimensions. If the first selected dimension (i.e. commitment) constitutes the transaction, then the last part is its relational dimension over the long term. The results of regression model showed a significant influence of emotional engagement on each facet of loyalty (regression coefficients (β) between 0.6 and 0.8 are positive or negative depending on the case) (see the figure below).

Table 4: Indices of Adjusted Model

CMINDF	GFI	NFI	CFI	RMSEA	AIC	ECVI
4.502	0.91	0.92	0.90	0.07	240.34	3.512

The willingness of consumers to behave in a consistent, cooperative and loyal manner towards the provider/brand depends heavily on their emotional commitment: commitment explains susceptibility to competitors' persuasion up to 57% ($\beta = -0.76$), integrative negotiation and claim a 49% ($\beta = 0.70$), the negative word of mouth from above 46% ($\beta = -0.68$), tolerance to punctual dissatisfaction at the height of 65 % ($\beta = 0.81$), and opportunism of up to 66% ($\beta = -0.81$). We can conclude that all the research hypotheses are confirmed.

Research implications and limits

If loyalty is central to ensuring continued success of the firm, the challenges of measuring it should now become one of the recurring concerns of managers and academics. In this research, loyalty is measured using a relational perspective that takes into consideration the commitment and behavioural responses such as the sub-dimensions underlying the overall concept of loyalty. Neither the behaviour itself, nor the attitude alone is enough to understand the true customer loyalty. To assess the loyalty of their customers, managers must adopt a mixed approach linking both the attitude and behaviour while

adopting a relational approach to measure the magnitude of this relationship in situations of adversity.

In this research, we tried to propose a measurement scale (called relational) for the concept of loyalty. Empirical validation of this scale has been done in the context of banking service providers. This may be a limit to the generalization of results. In order to ensure the external validity of this scale, it is necessary to test it in different research contexts.

Conclusion

The results of this research make it possible to confirm that sustainable affective commitment is one dimension of a customer's loyalty. If the first selected dimension constitutes the transaction's characterizations, then the last dimension (i.e., loyalty) represents its long term relational dimension. Loyalty functions as a force stabilizing the client's behaviour in the critical incidents due to a punctual dissatisfaction or a competitor's persuasion. The five events of loyalty (tolerance of punctual dissatisfaction, integrative negotiation and claim, negative word of mouth, sensitivity to competitors' persuasion, and opportunism) form the main reactions of the consumer in relation to a critical incident or a reason to change service provider. These factors help to comprehend the right sense of customers' loyalty.

Figure 1: Aggregate Model of Loyalty

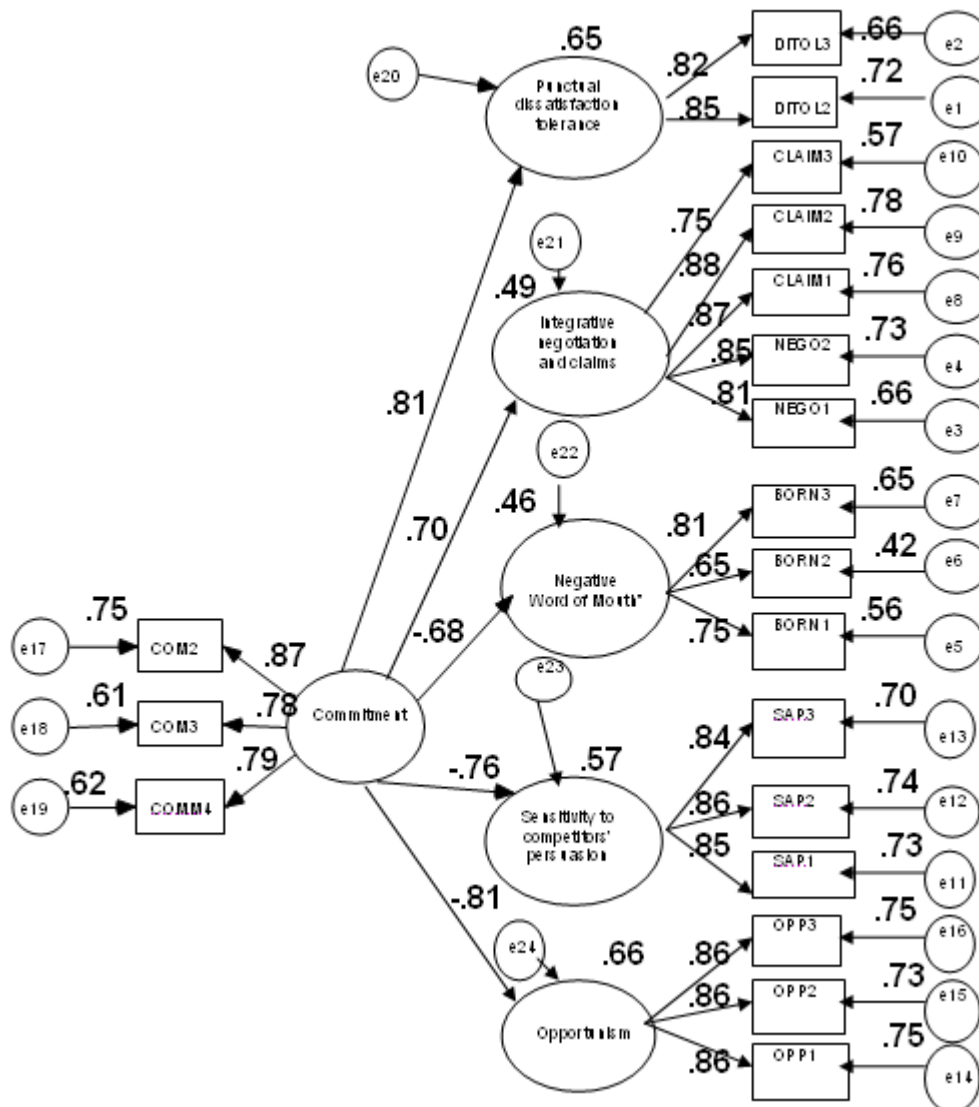

Bibliography

- [1]- Aurier P., C. Bénavent & Gilles N'Goala (2001), « Validité discriminante et prédictive des composantes de la relation à la marque », *Actes du Congrès de l'Association Française du Marketing*, Deauville, 22-23 Mai.
- [2]- Baldinger A. L. & J. Rubinson (1996), "Brand loyalty: the link between attitude and behaviour", *Journal of Advertising Research*, 36, 2, 22-34.
- [3]- Bitner, M. J. (1990), "Evaluating Service Encounters: The Effects of Physical Surroundings and Employee Responses", *Journal of Marketing*, 54, 2, 69-82.
- [4]- Churchill G. Jr., (1979), "A paradigm for developing better measures of marketing constructs", *Journal of Marketing Research*, Vol.16 (February), 64-73.
- [5]- Cohen P. C. J., Teresi J., Marchi M. & Velez C.N., (1990), "The problems in the measurement of latent variables in structural equations causal models", *Applied Psychological Measurement*, 14, 2, 183-196.
- [6]- Cunningham, Scott M. (1967), "Perceived Risk and Brand Loyalty," in *Risk Taking and Information Handling in Consumer Behavior*, ed. Donald F. Cox, Cambridge, MA: Harvard University Press, 507-523.
- [7]- Day G.S., (1969), "A two dimensional concept of brand loyalty", *Journal of Advertising Research*, 9, 3, 67-76.
- [8]- Dick A.S and K. Basu (1994), "Customer Loyalty: Toward an Integrated Conceptual Framework", *Journal of the Academy of Marketing Science*, 22, 2, 99-113.
- [9]- Drigotas S.M & C.E Rusbult (1992), "Should I stay or should I go? A Dependence Model of Breakups", *Journal of Personality and Social Psychology*, 62, 1, 62-87.
- [10]- Dubois B. & Laurent G. (1999), "A Situational Approach To Brand Loyalty", *Advances in Consumer Research*, 26, 1, 657-663.
- [11]- Dubois Bernard & Quaghebeur Alain (1997), « Les consommateurs font-ils ce qu'ils disent? », *Actes de l'Association Française de Marketing*, 13, 2, Toulouse, 891-95.
- [12]- Dufer J. et J.L. Moulins (1989), « La Relation entre la Satisfaction du Consommateur et sa Fidélité à la Marque: Un Examen Critique », *Recherche et Applications en Marketing*, 4, 2, 21-36.
- [13]- Dwyer F.R, Shurr P.H & Oh S. (1987), "Developing Buyer-Seller Relationships", *Journal of Marketing*, 51, 4, 11-27.
- [14]- Evrard Y., Pras B., Roux E. (2003), *Market: Etudes et recherches en marketing*, Dunod, 3eme ed.
- [15]- Filser M. (1994), *Le comportement du consommateur*, Paris, Dalloz.
- [16]- Fournier S. (1998), "Consumers and their Brands: Developing Relationship Theory in Consumer Research", *Journal of Consumer Research*, 24, 1, 343-353.
- [17]- Fournier. S & J. Yao, (1997), "Reviving Brand Loyalty: A reconceptualization within the framework of consumer-brand relationships", *International Journal of Research in Marketing*, 14, 5, 451-472.
- [18]- Frisou J. (1996), *Les théories marketing de la fidélité : un essai de validation empirique sur le marché des services e télécommunication*, Mémoire de DEA, IAE, USTL- Lille.
- [19]- Frisou J., (1998), «Vers une théorie éclectique de la fidélité des clients : le cas des services de Télécommunication», *Actes du 14ème Congrès International de l'Association Française du Marketing*, Mai, Bordeaux.
- [20]- Gilles N'Goala, (2007), "Customer switching resistance (CSR) The effects of perceived equity, trust and relationship commitment", *International Journal of Service Industry Management* Vol. 18 No. 5, 510-533
- [21]- Gurviez P. (1999), «Rôle de la confiance dans la relation consommateur – marque : proposition d'un modèle structurel», *NEGOCIA et Programme doctoral ESSEC d'AIX*.
- [22]- Hirshman A. O., (1970), *Exit, Voice, and Loyalty: Responses to Decline in Firms, Organizations, and States*, Harvard University Press.
- [23]- Jacoby & Kyner (1973), "Brand Loyalty vs. Repeat Purchasing Behaviour", *Journal of Marketing Research*, 10 (February), 1-9.
- [24]- Jacoby J. & R. Chesnut, 1978, *Brand loyalty: Measurement and management*, Wiley, New York.
- [25]- Jacoby J., (1971), "A model of multibrand loyalty", *Journal of Advertising Research*, 26, 11, 25-31.
- [26]- Jacoby J., (1975), "A brand loyal concept: Comments on comment", *Journal of Marketing research*, 11 (May), 484-487.
- [27]- Jooyoung Kim; Jon D Morris; Joffre Swait, (2008), "Antecedents of True Brand Loyalty", *Journal of Advertising*, 37, 2, 99-117.
- [28]- Jöreskog K & D Sörbom, (2001), "LISREL 8.30: User's reference Guide", SSI Scientific Software International.
- [29]- Keaveney S. M. (1995), "Customer switching behavior in service industries: an exploratory study", *Journal of Marketing*, 59, 2, 71-82.
- [30]- Kuo-Ming Chu, Cheng Shiu, (2009), "The Construction Model of Customer Trust, Perceived Value and Customer Loyalty", *The Journal of American Academy of Business*, Cambridge, 14, 2, 98-103.
- [31]- Laurent G. et Kapferer J. N. (1992), *La sensibilité aux marques*, Paris, Ed. d'Organisations.
- [32]- Moorman, Zaltman & Deshpande (1992), "Relationships between providers and users In market research: the dynamic of trust within and between organizations", *Journal of Marketing Research*, 29, 314-328.
- [33]- Morgan R.M & Hunt S.D (1994), "The commitment-trust theory of relationship marketing", *Journal of Marketing*, 58, 3, 20-38.
- [34]- Moulins J.-L. (1998), «Etat de fidélité et relation de fidélité : éléments de réflexion pour une nouvelle approche de l'échange», *Décisions Marketing*, 13, 67-73.
- [35]- N'Goala G. (2003), «Proposition d'une conceptualisation et d'une mesure relationnelle de la fidélité», *Actes du Congrès de l'Association Française du Marketing*, Gammarth, Tunisie, 9-10 mai.
- [36]- Newman J.W. & Werbel, R.A.(1973), "Multivariate Analysis of Brand loyalty for Major Household Appliances", *Journal of Marketing Research*, 10, 4, 404-409.
- [37]- Scholl R.W., (1981), "Differentiating organizational commitment for expectancy as a motivating force", *Academy of Management Review*, 6, 4, 589-599.
- [38]- Zouari, S. (2006), «Evaluation du système bancaire tunisien : Construction d'indice de stress», *Finance d'entreprise et finance de marché : quelles complémentarités ? Congrès International, Université de Poitiers*, 26 et 27 juin.

Appendix A: Variables' Measuring Items Sensitivity to Competitor's Persuasion

- SCP1: I would accept this proposal if it is my personal interest
- SCP2: I would not hesitate a moment to seize this opportunity if it is really blow for me
- SCP3: I would respond positively to this offer if it is a good opportunity for me

Opportunism

OPP1: I take this offer without saying anything to my financial adviser

OPP2: Although I am in a new loan from the competitor, I avoid telling my current banker

OPP3: I take this opportunity given to me but I will not reveal my true intentions to my personal bank.

Dissatisfaction Tolerance

DITOL1: I would be tolerant occasionally and I'll wait for better days

DITOL12: I agree to make a small sacrifice until the situation improves

DITOL13: I would be temporarily indulgent and still continue to address my usual financial advisor

Integrative Negotiation

NEGO1: I will inform my bank's staff how they can improve their products and align them on the competition

NEGO2: I will make constructive suggestions to my bank in order to improve the competitiveness of its products and services.

Negative Word of mouth

BON1: I would criticize my bank if one day an open discussion with my friends or my colleagues leads me to talk about banks

BON2: I discourage my friends and relations to do business with this bank

BON3: I will not hesitate to say negative things about my bank to some people around me.

Claims

CLAIM1: I will discuss with my bank's staff to find a compromise

CLAIM2: I will solve this problem with the staff of my bank quickly.

CLAIM3: I will try to solve this problem with the staff of my bank that I know.

Commitment

COMM1: As a customer, I really feel a full member of my bank

COMM2: I am particularly attached to my bank

COMM3: I will be happy to remain a client of the bank

COMM4: I am proud to tell others that I am a customer of the bank.