



Electrical Engineering

Elixir Elec. Engg. 67 (2014) 21318-21320

Elixir
ISSN: 2229-712X

Power quality improvement using three phase harmonic filter and PLL technique

Shraddha Tiwari^{1,*} and A. K. Sharma²

¹HVPS Engineering, Jabalpur Engineering College, Jabalpur, India.

²Department of Electrical Engineering, Jabalpur Engineering College, Jabalpur, India.

ARTICLE INFO

Article history:

Received: 11 July 2013;

Received in revised form:

20 January 2014;

Accepted: 1 February 2014;

Keywords

Harmonic,

PLL,

Three Phase Harmonic Filter.

ABSTRACT

In this proposed work a new technique has been developed for reducing total harmonic distortion using THREE PHASE HARMONIC FILTER and PHASE LOCK LOOP (PLL) technique in HVDC system. This work model implemented in simulation work. Harmonic filter are shunt elements that are used in power systems for decreasing voltage distortion and for power factor correction. Nonlinear elements such as power electronic converters generate harmonic currents or harmonics voltages which are injected into power system. The resulting distorted currents flowing through system impedance produce harmonic voltage distortion. Harmonic filters reduce distortion by diverting harmonic currents in low impedance paths. Harmonic filters are designed to be capacitive at fundamental frequency, so that they are also used for producing reactive power required by converters and for power factor correction. Phase Lock Loop technique is used for harmonic reduction of the system and improving power quality of the whole system. Phase Lock Loop is synthesized the new frequency. In this system reactive power compensation is done by the two types of compensation devices are shunt compensation and series compensation.

© 2013 Elixir All rights reserved

Introduction

With the advent of power semiconductor switching devices, like thyristors, GTO's (Gate Turn off thyristors), IGBT's (Insulated Gate Bipolar Transistors) and many more devices, control of electric power has become a reality. Such power electronic controllers are widely used to feed electric power to electrical loads, such as adjustable speed drives (ASD's), furnaces, computer power supplies, HVDC systems etc. The power electronic devices due to their inherent non-linearity draw harmonic and reactive power from the supply. In three phase systems, they could also cause unbalance and draw excessive neutral currents. The injected harmonics, reactive power burden, unbalance, and excessive neutral currents cause low system efficiency and poor power factor. In addition to this, the power system is subjected to various transients like voltage sags, swells, flickers etc. These transients would affect the voltage at distribution levels. Excessive reactive power of loads would increase the generating capacity of generating stations and increase the transmission losses in lines. Hence supply of reactive power at the load ends becomes essential. Power Quality has become an important issue since many loads at various distribution ends like adjustable speed drives, process industries, printers; domestic utilities, computers, microprocessor based equipments etc. have become intolerant to voltage fluctuations, harmonic content and interruptions. Power Quality mainly deals with issues like maintaining a fixed voltage at the Point of Common Coupling for various distribution voltage levels irrespective of voltage fluctuations, maintaining near unity power factor power drawn from the supply, blocking of voltage and current unbalance from passing upwards from various distribution levels, reduction of voltage and current harmonics in the system and suppression of excessive supply neutral current. Conventionally, passive three phase parallel RLC Branch Mask Branch type RL filters and fixed

compensating devices with some degree of variation like thyristor switched capacitors, thyristor switched reactors were employed to improve the power factor of ac load.

Phase Lock Loop (PLL)

A frequency synthesizer allows the designer to generate a variety of output frequencies as multiples of a single reference frequency. The main application is in generating local oscillator (LO) signals for the up- and down-conversion of RF signals. The synthesizer works in a phase-locked loop (PLL), where a phase/frequency detector (PFD) compares a feedback frequency with a divided-down version of the reference frequency. The PFD's output current pulses are filtered and integrated to generate a voltage. This voltage drives an external voltage-controlled oscillator (VCO) to increase or decrease the output frequency so as to drive the PFD's average output towards zero.

Three Phase Harmonic Filter

Three-phase harmonic filters are shunt elements that are used in power systems for decreasing voltage distortion and for power factor correction. Nonlinear elements such as power electronic converters generate harmonic currents or harmonic voltages, which are injected into power system. The resulting distorted currents flowing through system impedance produce harmonic voltage distortion. Harmonic filters reduce distortion by diverting harmonic currents in low impedance paths. Harmonic filters are designed to be capacitive at fundamental frequency, so that they are also used for producing reactive power required by converters and for power factor correction. In order to achieve an acceptable distortion, several banks of filters of different types are usually connected in parallel. The most commonly used filter types are Band-pass filters, which are used to filter lowest order harmonics such as 5th, 7th, 11th, 13th, etc. Band-pass filters can be tuned at a single frequency (single-tuned filter) or at two frequencies (double-tuned filter).

Tele:

E-mail addresses: shraddhatiwari1706@gmail.com

© 2014 Elixir All rights reserved

- High-pass filters, which are used to filter high-order harmonics and cover a wide range of frequencies. A special type of high-pass filter, the C-type high-pass filter, is used to provide reactive power and avoid parallel resonances. It also allows filtering low order harmonics (such as 3rd), while keeping zero losses at fundamental frequency.

The Three-Phase Harmonic Filter is built of RLC elements. The resistance, inductance, and capacitance values are determined from the filter type and from the following parameters:

- Reactive power at nominal voltage
- Tuning frequencies
- Quality factor. The quality factor is a measure of the sharpness of the tuning frequency. It is determined by the resistance value.

The four types of filters that can be modeled with the Three-Phase Harmonic Filter block are shown below:

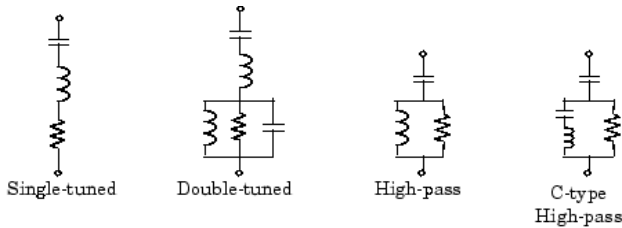

Three Phase Harmonic Filter

Passive Filter

The filters used for the earlier examples were all made up of passive components: resistors, capacitors, and inductors, so they are referred to as passive filters. A passive filter is simply a filter that uses no amplifying elements (transistors, operational amplifiers, etc.). In this respect, it is the simplest (in terms of the number of necessary components) implementation of a given transfer function. Passive filters have other advantages as well. Because they have no active components, passive filters require no power supplies. Since they are not restricted by the bandwidth limitations of op amps, they can work well at very high frequencies. They can be used in applications involving larger current or voltage levels than can be handled by active devices. Passive filters also generate little noise when compared with circuits using active gain elements. The noise that they produce is simply the thermal noise from the resistive components, and, with careful design, the amplitude of this noise can be very low.

Active Filters

Active filters use amplifying elements, especially op amps, with resistors and capacitors in their feedback loops, to synthesize the desired filter characteristics. Active filters can have high input impedance, low output impedance, and virtually any arbitrary gain. They are also usually easier to design than passive filters. Possibly their most important attribute is that they lack inductors, thereby reducing the problems associated with those components. Still, the problems of accuracy and value spacing also affect capacitors, although to a lesser degree. Performance at high frequencies is limited by the gain-bandwidth product of the amplifying elements, but within the amplifier's operating frequency range, the op amp-based active filter can achieve very good accuracy, provided that low-tolerance resistors and capacitors are used. Active filters will generate noise due to the amplifying circuitry, but this can be minimized by the use of low-noise amplifiers and careful circuit design.

Voltage control and stability

- * Power swing damping

- * In power distribution:

- * Stabilized voltage at the receiving end of long lines
- * Increased productivity as stabilized voltage better utilizes capacity
- * Reduced reactive power consumption, gives lower losses and eliminates higher or penal tariffs
- * Balanced asymmetrical loads reduce system losses
- * Fewer stresses in asynchronous machinery
- * Enables better use of equipment (particularly transformers and cables)
- * Reduced voltage fluctuations and light flicker
- * An SVC typically comprises a transformer, reactors, capacitors and bi-directional thyristor valves. There is a variety of main circuit arrangements. Figures 4 and 5 show two common schemes:

- * FC/TCR – Fixed Capacitor (filter) / Thyristor-Controlled Reactor

- *TSC/TCR – Thyristor-Switched Capacitors/Thyristor-Controlled Reactor

With the advent of thyristor control, the usefulness of series compensation has been augmented further. Applications not spoken of hitherto in conjunction with series compensation such as active power flow control, damping of power oscillations, and last, but not least, mitigations of sub-synchronous resonance, are all now a practical reality. The latter item, in particular, had for a long time been in search of a good and practicable solution, and with sub-synchronous resonance no longer an obstacle, it can be expected that the usefulness of series compensation will be appreciated even more than before and the technology put to even more widespread Use If damping is poor over a transmission line, minor system disturbances can get active power oscillations started between generator systems at either ends of the line. These oscillations, usually appearing at low frequencies (<1 Hz), as a rule are more pronounced at higher loads than at lower loads and as a matter of fact act as a limitation on effective power transmission capability of interconnections between generating areas. This could be a serious drawback for instance in conjunction with power corridors between countries or between regions within countries. The plant can in most cases be designed completely without harmonic filters. In some cases where the requirements on high order harmonics are very stringent a small high pass link may be necessary. The risk for resonant conditions is therefore negligible. This property makes the SVC Light suitable for easy relocation to other sites at changing network demands.

Complete Simulation Model

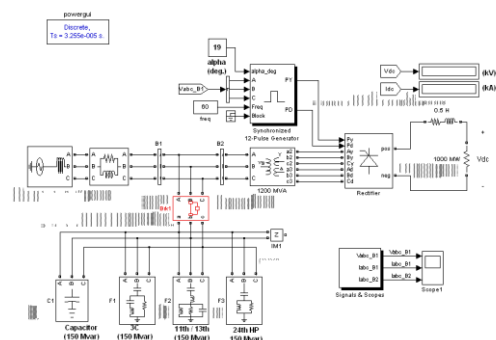

Power Quality Improvement Using Three Phase Harmonics Filter and PLL Technique

Simulation Result-- We have simulated the system with Three Phase Harmonic filter and Phase Lock Loop technique in the pc with Microsoft XP, with MATLAB R2009a(7.8.0).In the

simulation result , graph of time Vs voltage and time Vs current shown in results. FFT analysis result shows the total harmonic distortion in the system.

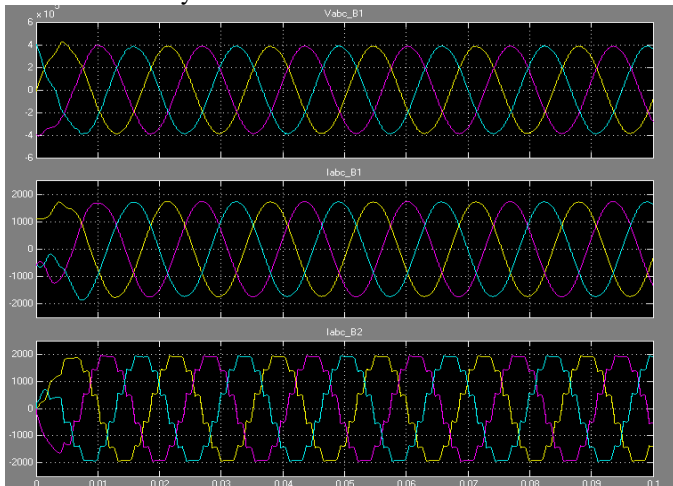

Harmonics distortion & Improve results

FFT Analysis Result

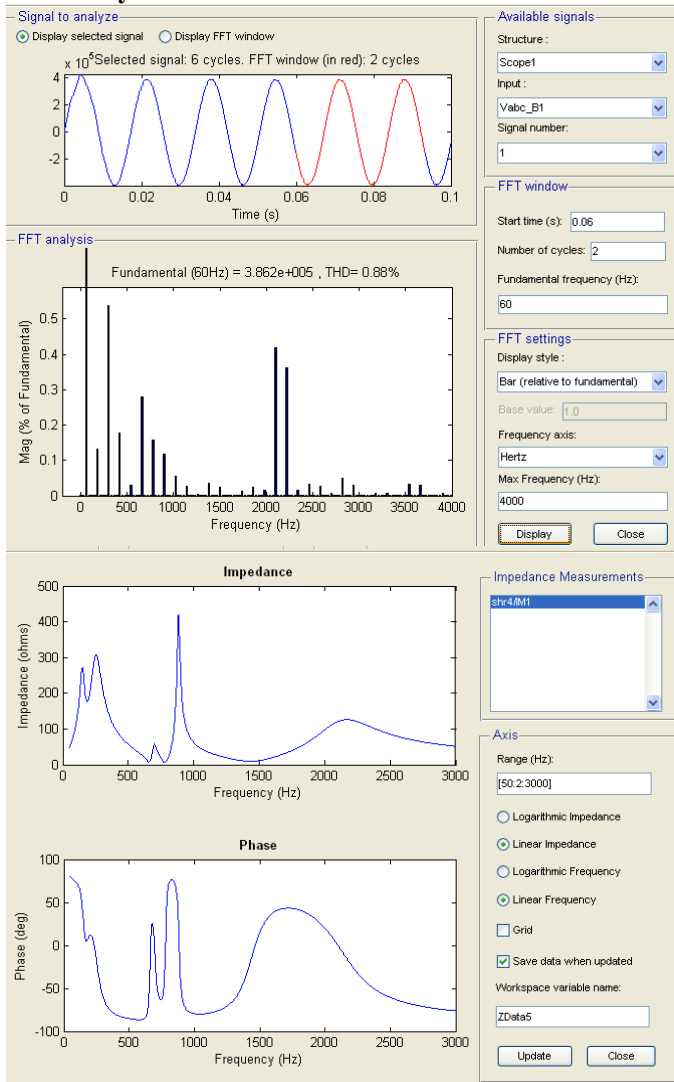

Conclusion

The power quality problems such as voltage dips, swells and interruptions, consequences, and mitigation techniques of custom power electronic device the effects of Harmonics in the Power System and steps to reduce the effects of Harmonics. This project will also explain how Harmonic distortion is one of the most important problems associated with power quality and creates several disturbances to the Power System. It includes the Harmonic reduction techniques to improve the power quality and it will also include the simulation for the same. are used in the Power System. During the transformation from DC to AC, harmonics affect the the power quality a lot. How harmonic reduction will improve the power quality.

References

[1] Voltage stability of power systems: concepts, Analytical tools, and industry experience, IEEE Special Publication 90th 0358-2 PWR 1990.
 [2] N.G Hingorani, 2011, "Understanding facts: concepts Technology of flexible AC transmission system", IEEE Power Engg. IEEE press, Wiley India
 [3] L. Gyugyi, "Power Electronics in Electric Utilities: Static Var Compensators", Proceedings of the IEEE, Vol. 7 No.4, pp. 483-494, 1988.
 [4] B. Scott, "Review of load flow calculation methods',Pro IEEE 62 (7) (1974) 916929.
 [5] A. J. Wood and B. F Wollen berg, "Power Generation Operation and Control", John Wiley and Sons, New York, USA 1984.
 [6] Bouktir T., Belkacemi M., Zehar K "Optimal power flow using modified gradient method", Proceedings ICEL 2000, U.S.T Oran, Algeria. pp. 436-442,2000.
 [7] N. Hingorani, L. Gyugyi, "Understanding FACTS, Concepts and Technology of Flexible AC Transmission Systems", IEEE Press, New York, 2000.
 [8] Lennart Angquist, Gunnar Ingestrom, Hans Ake onsson, "Dynamical performance of TCS schemes", CIGRE 2006 14:302, ABB power system.
 Roland E. Best, "Phase-Locked Loop: Design, Simulation, and Applications", 5thed, McGRAW-Hill, 2003 | Robert L. Boylestad, and Louis Nashelsky, "Electronic Devices and Circuit Theory", 9thed, Prentice Hall, 2006
www.poweronline.com
www.sandc.com
www.powerquality.com
www.mathworks.com