



A Non-isolated modular inverter topology on DC bus for micro grid

S.Sheikameer Batch* and B.Hemananth

Department of EEE, Sri Eshwar College of Engineering.

ARTICLE INFO

Article history:

Received: 28 February 2014;

Received in revised form:

19 June 2014;

Accepted: 29 June 2014;

Keywords

Gridconnected,
Microgrid,
Photo-voltaic generation,
Fuel cell generation,
Transformerless inverter.

ABSTRACT

In order to increase the reliability and efficiency of distributed micro-generation a modular grid-connected inverter system is proposed. It consists of a modular DC-DC converter and modular DC-AC converter. Output of the DC-DC converter and input of the DC-AC inverter is connected with a DC bus. The By using the DC-DC converter voltage can be stepped up and Maximum power point tracking can be achieved In this system no transformer is used in the inverter side to inject the voltage into the grid. Here the Voltage is injected in the grid using inductor filter. The practicability of the proposed system has been verified by simulation results and hardware.

© 2014 Elixir All rights reserved

Introduction

In rural and remote areas it is difficult to connect the electrical grid and it is uneconomical. The micro grid concept is more economical in which the remote areas will be connected electrically using the renewable energy sources available. A micro-grid is a semi independent grouping of generating sources and controllable end-use loads[1]. This approach allows for local control of distributed generation thereby reducing or eliminating the need for central dispatch [2].

The idea of a localized power grid or microgrid fits into this overall strategy in several key ways. First, the more power produced on a local level, the less a community will need to import from outside power plants or leech off the network. Many of the nation's energy woes are due to the electrical equivalency of a run on the bank. Temperatures suddenly skyrocket, so more people crank up the air conditioning -- which puts a huge drain on the grid. If there's not enough to go around, then not everyone gets power -- at least until sufficient energy becomes available elsewhere on the grid.[3]

They are generally, however, grouped into 3 types: DC coupled, AC coupled and AC and DC coupled configurations. In a DC coupled configuration, all energy sources are linked together on the DC side before being connected to the AC side (loads and/or grid) via inverters. Nowadays, DC coupled configurations are used mostly for smaller hybrid systems upto a certain size (a few kW), depending on various external parameters. Solar home systems are a simple form of a standalone DC coupled micro-grid configuration, where only PV generators are used to provide energy to consumers, such as houses or small first aid stations at the scale of a village The power range for a DC coupled configuration is extremely broad and can be used cost effectively for various off-grid applications. Depending on the application type and available energy resources, different conventional and renewable energy generators could be added to the system to form a hybrid energy system. [2]

A hybrid energy system usually consists of more renewable source will not be available in summer and solar power will not

be available during the cloudy days. So the efficiency of the hybrid system is reduced due to climatic changes

In order to make the hybrid system 100%reliable and increase the efficiency the following system is proposed in the paper.

Overview Of Configurations Connected To The Grid

The configurations of a PV generation system are the centralized structure, the string structure, the multistring structure, and the ac-module structure, as shown in Fig.

Centralized structure

Initially, the interface between Photovoltaic power supply and the grid rely on the centralized inverter technology, as shown on Fig.1(a). Inverters are connected in into series, called strings, generating a sufficient high voltage to avoid amplification. All strings are then connected in parallel to support high power to output. Only one inverter is utilized to interface the grid. This technology suffers from disadvantageous issues, including high voltage DC cable from a big number of strings to the inverter and losses in string diodes. This structure is also limited from Maximum Power Point (MPP) Tracking and controlling mismatch between strings so individual PVs, resulting in low efficiency and reliability. The nonflexible design makes it less appealing in mass production. With all these issues, this technology is not used in new solar systems installation.[4] installation, the maintenance requirements can increase the cost and discourage wide usage. To keep inverter boxes watertight and use components that have large temperature ambient is major concerns. It will be necessary to develop a system that can detect failure of any micro-inverter and isolate it immediately. This type of inverter has recently become emerging product and promised a remarkable market share in future [4].

As shown in Fig. 2, a complete modular structure of a non isolated grid connected inverter consists of modular dc-dc converters and modular dc-ac inverters. The sources are connected with their own dc-dc converter to a common dc bus, instead of a centralized inverter ,the inverters are distributed and connected in the dc bus. Voltage step-up and MPPT are

achieved by the dc–dc converters.. The inverter modules inject a sinusoidal ac current into the utility grid with unity power factor with the regulated .Here the voltage is injected with inductors.

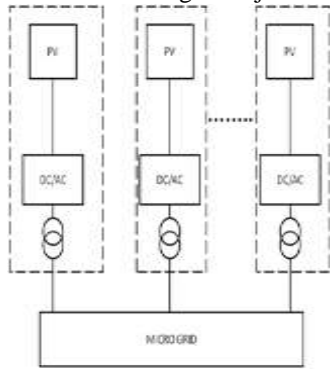

Fig 1 (d) AC module structure

Proposed System Configuration

Each module unit in this generation system has independent Functions. Due to its modular structure, this generation system have the following characteristics.

- 1) The dc–dc converters operate with their own MPPT, So that each source has independent MPP. Hence, high conversion efficiency of PV arrays is assured.
- 2) The inverters are operated in parallel , so that load sharing for each inverter module can be done and that increases efficiency .
- 3) Plug-in is available.
- 4) More number of inverters can be added in future
- 5) The dc–dc converter modules and inverter modules are suitable for large-scale standardized production. Therefore, this generation system is cost effective.

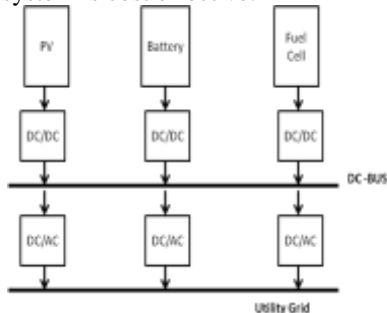

Fig 2 Configuration of proposed topology

This modular system consists of DC–DC converter modules and DC–AC inverter modules. The output of the source is given to the DC-DC boost converter. Boost converter steps up the DC voltage, MPPT can be easily achieved by using DC –DC converter. The output of the DC-DC Converter is given to the DC bus.

In the above system if any one of the system gets fault, it will not affect the other system and they will continue to operate in good condition. So the overall efficiency will be increased. Here instead of using transformers to fed into the grid two inductors are used to inject the power.

In this system the input voltage is stepped upto 230v DC using boost converter and then it is converted to 230V AC using H-Bridge Inverter .

The fig 3 shows the circuit diagram of DC-AC inverter where two inductors are connected in each bridge which in turn connected to the utility grid

The fig 4 represents the DC-DC boost converter in which the inductor and capacitor value can be changed to get the desired voltage

To get an output voltage of 230V DC the inductance and capacitance value should be found. The following calculations are done to find out the values of the inductance and capacitance Here input Voltage is assumed as 12V and resistance sa 10 Ω

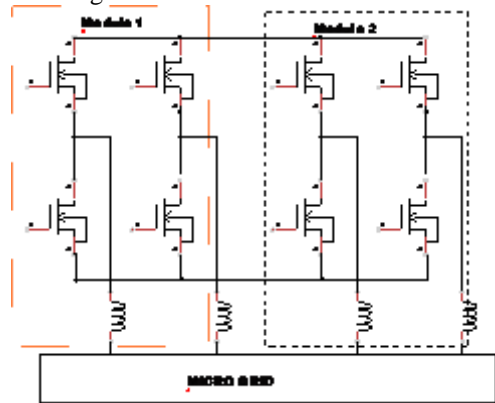

Fig 3. DC –AC inverters with inductors

Design of the Boost Converter

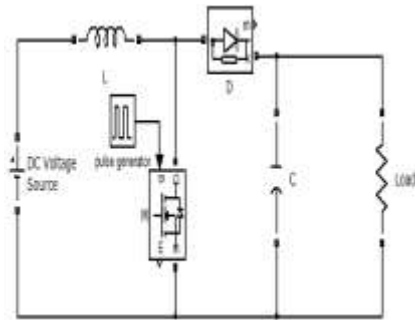

Fig 4. DC-DC Boost converter

$$V_o = V_i / (1 - \delta) \tag{1}$$

$$V_i = 12V; V_o = 230V; R_s = 10 \Omega; \Delta_i = 0.5A; f = 50Hz$$

$$230 = 12 / (1 - \delta) \tag{2}$$

$$\delta = 0.948 \tag{3}$$

$$L = (V_i \times \delta) / (f \times \Delta_i) \tag{4}$$

$$L = (12 \times 0.948) / (3000 \times 0.5) \tag{5}$$

$$L = 7.5mH \tag{6}$$

$$C = \delta / (f \times R_s) \tag{7}$$

$$C = 0.948 / (3000 \times 10) \tag{8}$$

$$C = 15\mu F \tag{9}$$

By using the above values an boost converter has been designed

Simulation Results

In order to check the reliability of the proposed structure the experiment been done using MATLAB for the circuit shown in fig 3. A simulation diagram has been drawn using Matlab/ Simulink which consists of two modules .Each modules consists of a separate source, DC-DC converter and DC-AC inverter

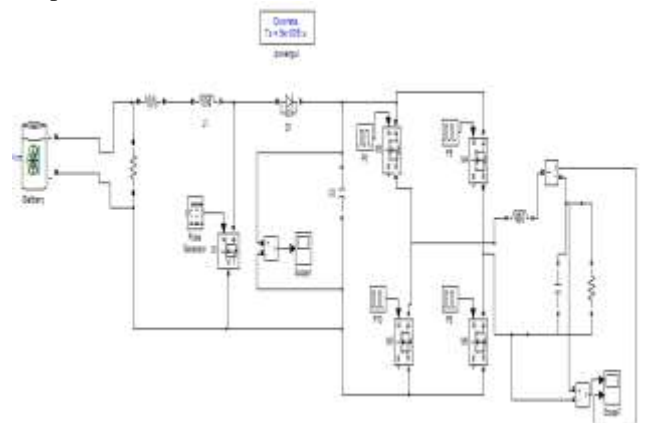

Fig 5(a) Simulation diagram for non isolated inverter(Single module)

The figure 5(a) , 5(b) shows the simulation diagram for the proposed modular inverters

Table I
Parameters of simulation diagram

S.no	Parameters	Value
1	Input voltage	12V
2	Resistance (converter side)	10Ω
3	Capacitance	15μF
4	Output voltage	230V
5	Frequency	50Hz

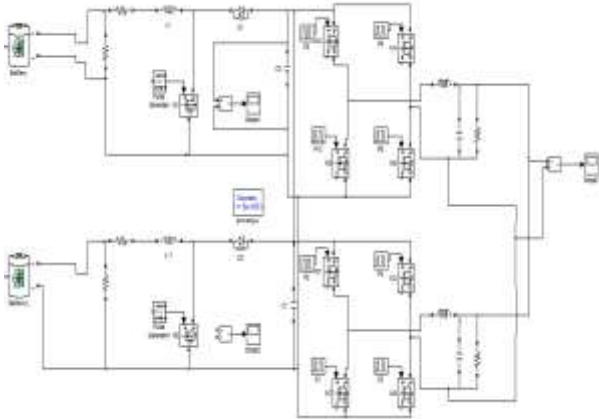

Fig 5(b) Simulation diagram for non isolated inverter(Two modules)

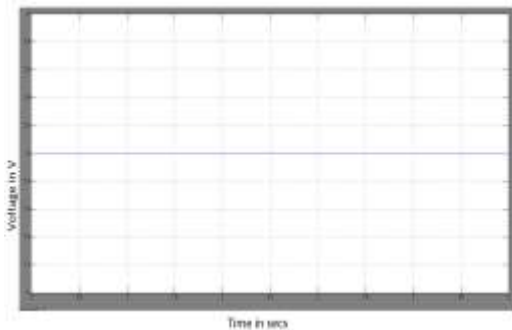

Fig 5(c) Input voltage

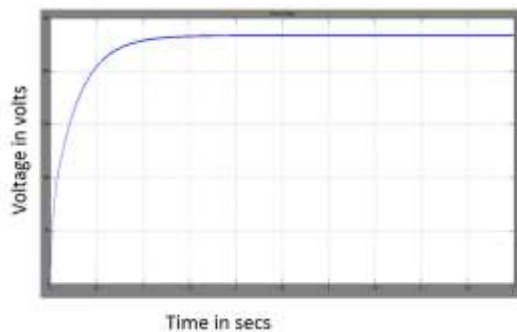

Fig 5(d) Output voltage of DC-DC Converter

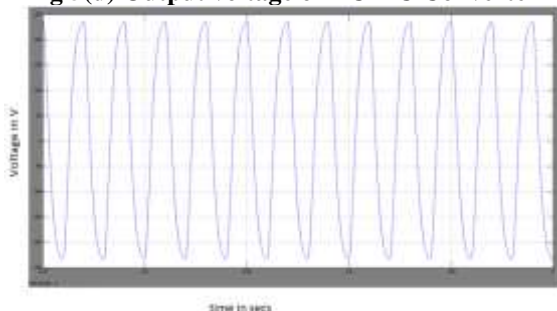

Fig 5(d) Output voltage of DC-AC Inverter

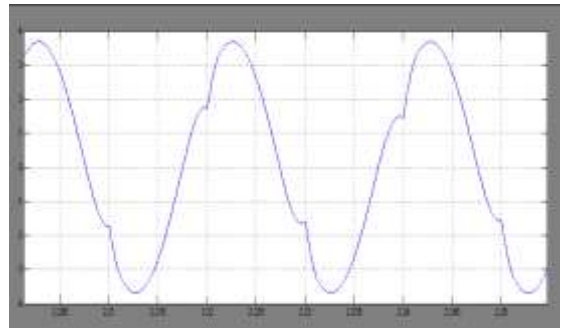

Fig 5(e) Output current of DC-AC Inverter

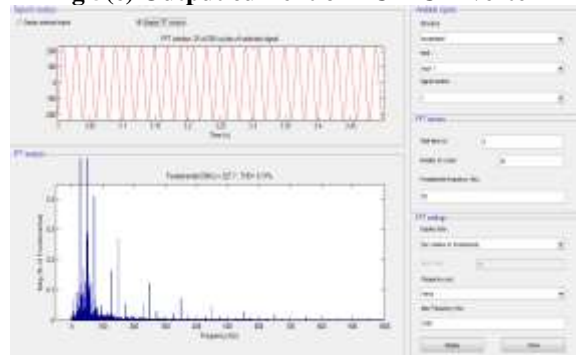

Fig 5(f) Harmonic Analysis of Output Voltage

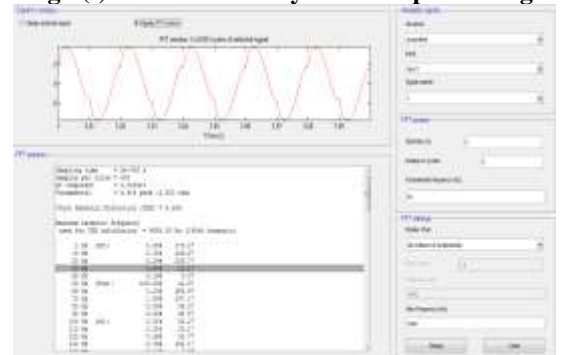

Fig 5(g) Harmonic Analysis of Output current

The Fig 5(c) shows the Input voltage which is 12VDC. The Fig 5(d) shows the Output voltage of DC-DC Converter which is 230VDC. The Fig 5(e) shows the Output voltage of Output voltage of DC-AC Inverter which is 230V AC. The Fig 5(f) shows the Harmonic Analysis of Output Voltage where THD=0.31% and The Fig 5(g) shows the Harmonic Analysis of Output current where THD=8.5%

Hardware Results

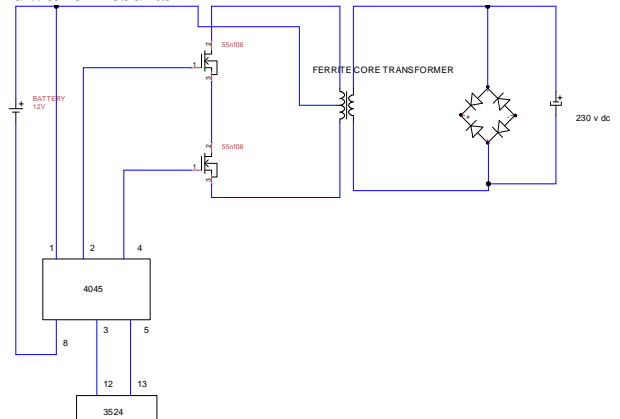

Fig 6(a) DC-DC Converter Hardware Circuit

The Fig 6(a) shows the DC-DC converter hardware circuit .Here two Mosfets are used ,pulse is given through 4045 which is a driver IC,3524 is a PWM IC which is fed to 4045.The output of Mosfet is connected to ferrite core transformer.

Mosfet produces a pulsating DC which is given to the ferrite core transformer. Here the voltage is stepped up to 230V Pulsating DC. Bridge rectifier is used to convert the pulsating DC into pure DC

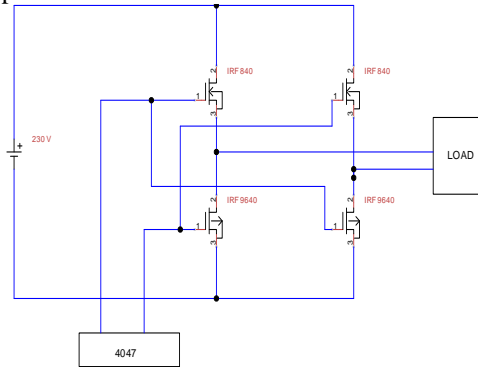

Fig 6(b) DC-AC Inverter Hardware Circuit

The Fig 6(b) shows the DC-AC converter hardware circuit. Here H-bridge configuration is used. In each leg one P-Channel Mosfet (IRF 9640) is used and one N-Channel Mosfet (IRF 840) is used. Pulse is given to the Mosfet through the 4047 IC.

Here 230V DC is converted into 230V AC and fed to the load.

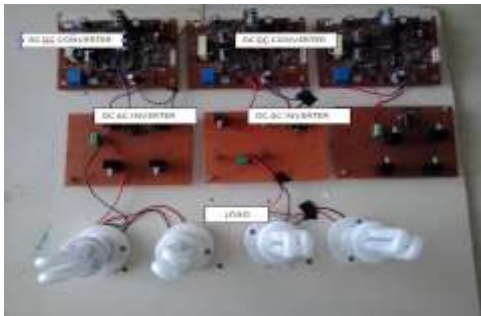

Fig 6(c) Hardware Photograph

The proposed system is very reliable and increases the efficiency, which is showed in experimental results.

Conclusion

As it is a non isolated type inverter it reduces the cost of the prototype. Due to its modular structure, even if any one of the source or module is disconnected the system continues to work

in good manner. Thus it shows that system is very reliable. It has excellent scalability due to its modular structure.

The following things are the characteristics of the system

- Hence, high conversion efficiency of PV arrays is assured.
- 2) The inverters are operated in parallel, so that load sharing for each inverter module can be done and that increases efficiency
 - 3) Plug-in is available.
 - 3) Plug-in is available.
 - 4) More number of inverters can be added in future
 - 5) The dc-dc converter modules and inverter modules are suitable for large-scale standardized production. Therefore, this generation system is cost effective.

[1] Robert H. Lasseter, Paolo Piagi "Microgrid: A Conceptual Solution" PESC'04 Aachen, Germany 20-25 June

[2] Sengprasong Phrakonkham, Jean-Yves Le Chenadec, Demba Diallo, Ghislain Remy and Claude Marchand "REVIEWS ON MICRO-GRID CONFIGURATION AND DEDICATED HYBRID SYSTEM OPTIMIZATION SOFTWARE TOOLS: APPLICATION TO LAOS", ENGINEERING JOURNAL : VOLUME 14 ISSUE 3 ISSN 0125-8281,2010.

[3]<http://science.howstuffworks.com/environmental/energy/microgrid1.htm>

[4] J. M. A. Myrzik, and M. Calais, "String and Module Integrated Inverters for Single-phase Grid Connected Photovoltaic Systems - A Review", IEEE Bologna Conference 23-26, Bologna, Italy

[5] Hamrouni* and A. Chérif, "Modelling and control of a grid connected photovoltaic system" *Revue des Energies Renouvelables* Vol. 10 N°3 (2007) 335 – 344

[6] Y. Chen and K. M. Smedley, (2004), "A cost-effective single-stage inverter with Maximum Power Point Tracking," IEEE Trans. Power Electron., vol. 19, no. 5, pp. 1289–1294.

[7] Y. Xue, L. Chang, S. B. Kjaer, J. Bordonau, and T. Shimizu, (2004) "Topologies of single-phase inverters for small distributed power generators: An overview," IEEE Trans. Power Electron., vol. 19, no. 5, pp. 1305–1311.

[9] S. B. Kjaer, J. K. Pederson, and F. Blaabjerg, (2005), "A review of single-phase grid-connected inverters for photovoltaic modules," IEEE Trans. Ind. Appl., vol. 41, no. 5, pp. 1292–1306