



Analysis and overview of Flooding Attack in Optimized link State Routing protocol

Akshat Khaskalam and Sandeep Sahu
Shri Ram Institute of Technology, Jabalpur, India.

ARTICLE INFO

Article history:

Received: 4 March 2013;

Received in revised form:

5 December 2014;

Accepted: 17 December 2014;

Keywords

Network coding;
Wireless Networks;
Network re- source efficiency;
Topology information dissemination;
Broad- cast all-to-all;
Multi-Point Relays.

ABSTRACT

During this last decade, mesh networks have experienced strong growth due to their ability to provide an additional and complementary support for existing infrastructure communication systems. In such a network, routers are supposed to be fixed for short (e.g. public safety deployment) or long (e.g. network operator extension) period. This relative stability of infrastructure makes proactive routing protocols appropriate. One of the well known proactive routing protocols is OLSR (Optimized Link State Routing), which routing decisions are based on exchanges of topology information using all-to-all flooding of local information in order for each router to build a global knowledge of the topology. This study first goal is to improve the performance of topology information flooding in OLSR by introducing network coding techniques, which leads to a decrease of signaling overhead.

© 2014 Elixir All rights reserved

Introduction

Rapidly deployable mesh networks have gained wide popularity in recent years due to their deployment ease and low cost implementation. They are used in many application areas such as communication networks for public security forces and temporary extensions of operator networks.

Given that mesh networks are self-organizing, data forwarding between users is a challenge and requires considerable efforts from the scientific community. Several types of routing protocols have been proposed, each with its own variants. Most common routing protocols are either reactive ([1], [2], [3], [4]) or proactive ([5], [6], [7]), even if some hybrid routing protocols exist ([8], [9]). On one hand, reactive protocols do generate control messages only when necessary. Thus, mechanism for route computation is activated only when a request to establish communication occurs. On the other hand, proactive protocols exchange control messages on a regular basis in order to insure up-to- date routing tables. It is therefore clear that reactive routing protocols generate less control messages than proactive ones, but require more delay for communication establishment. The choice of using either type of routing is based on a tradeoff between network overhead introduced by topology dissemination and the time for communication establishment one wishes to tolerate. In cases where mobility exists but is not permanent nor very important, proactive protocols are more advantageous, especially if energy, resources, memory, and CPU are not critical, as it is the case in ad hoc network consisting of emergency vehicles (e.g. fire trucks, police cars, or ambulances) in public safety interventions. In such a situation, rather it is the radio resource that should be saved. Thus, the exchange of control messages, considered as overload since it does not convey data information, should be optimized in order to minimize radio resource waste.

Economy of radio resources in a proactive routing protocol requires the amount of control messages that allow operation of the protocol to be optimized. In this paper, we focus on OLSR (*Optimize Link State Routing protocol*), the most used proactive routing protocol. OLSR operates in four steps: (i) local topology discovery, ensured by the exchange of HELLO messages between neighboring nodes, (ii) local information sharing by TC (*Topology Control*) diffusion over the whole network, (iii) route calculation through shortest path algorithm, and (iv) routing table update according to route calculation.

In this paper, we focus on TC message diffusion within the network and investigate how to optimize radio resource usage while achieving a successful dissemination, i.e. all nodes have the required information for global network knowledge. Initially, TC message diffusion consisted in PF (*Pure Flooding*), where every node broadcasts every message it receives. Obviously, PF generates transmission redundancy and one of the major impacts of such a protocol is the radio resource waste to achieve complete dissemination.

In order to make diffusion of topology information more efficient, several techniques, which actually reduce signaling overhead, have been proposed. Traditionally, this all-to- all broadcast is implemented by letting each node store and forward received packets. Some of these techniques are based on the selection of a subset of nodes, forming a CDS (*Connected Dominating Set*) [10], in charge of relaying topology information. Among these methods, we can mention the so called MPR (*Multi point Relay*), which has been adopted by OLSR. More recent proposals are based on information coding techniques, especially NC (*Network Coding*) mechanisms, which aim to reduce the amount of data required to transmit information in the network. In NC-based approaches, each node overhears packets transmitted from neighboring

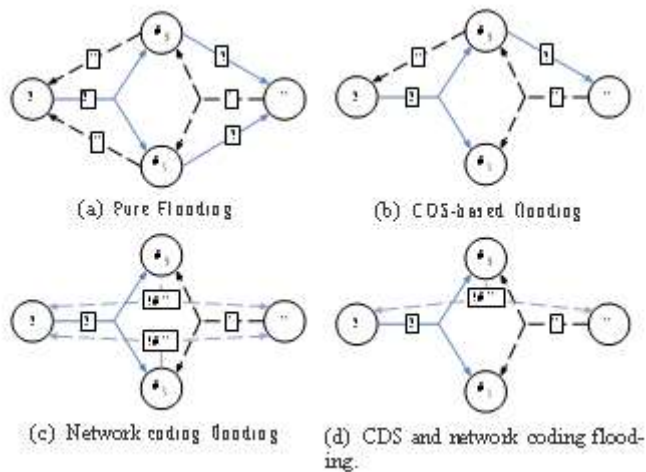

Figure 1. This figure compares, in a simple example, the various existing techniques and shows the number of generated packets for a total diffusion. In this example, Pure Flooding needs 6 transmissions when Connected Dominating Set based solution and Network Coding needs 4. The combination of both Connected Dominating Set based flooding and Network Coding requires only 3 to achieve the same goal

nodes, combines them, and forwards the resulting packets to its neighbors. The goal is to generate fewer transmissions, which helps to save radio resources and energy. Finally, some works strive to reduce redundant transmissions by combining MPR-based flooding and Network Coding either deterministic [11] or random [12]. The combination of CDS-based flooding and network coding shows considerable performance gains for topology information dissemination. Figure 1 illustrates, by a simple example, the concept and benefits of previously described approaches: Pure Flooding, CDS-based Flooding, Network Coding, and CDS-based Flooding using Network Coding.

The purpose of this paper is to summarize existing solutions in order to explore possible optimization of TC message dissemination in OLSR. The goal here is not to radically change the functioning of OLSR but to maintain an efficient dissemination of TC messages by reducing the induced overhead. The contributions of this paper are the following:

- Overview of existing TC message diffusion proposals for OLSR, either based on relay selection and/or network coding,
- Proposal of new methods not yet explored combining Connected Dominating Set and Network Coding approaches,
- Performance gain assessment of all approaches, existing and proposed ones, by simulations, under the same conditions and parameters, and Analysis of the results and enlightenment about some Network Coding unexpected behaviors.

Describe main flooding solutions developed either for OLSR or for other goals. In Section III, we summarize existing techniques and describe novel approaches proposed within this paper that aim at filling gaps. Performance comparison between existing and new proposed solutions is performed within Section IV, while Section V discusses the results and concludes the paper.

Flooding Algorithms

A. Preliminary definitions

Let us consider an ad hoc network represented by a graph $G = (V, E)$ where V is the set of wireless nodes and E the set of edges. Each node of V is characterized by its geographic coordinates and the power of transmission.

This paper is organized as follows. In Section II, we Circle of center u . For all nodes v in this circle there is exists an edge in E , noted (u, v) . We call 1-hop neighbors of u , noted $N(u)$, nodes v such as $\forall v \in V, \exists (u, v) \in E$ and 2-hop neighbors of u , noted $N(N(u))$, nodes w such as $\forall w \in N(N(u)), \exists v \in N(u) | \exists (v, w) \in E$. Obviously, a node in $N(N(u))$ can also belong to $N(u)$.

1) *Local topology discovery*: Periodically, node u sends an update message towards nodes in $N(u)$ and naturally, receives update message from nodes in $N(u)$. This update message, called HELLO message in OLSR, contains the list of nodes of $N(u)$. After receiving all update messages from $N(u)$ nodes, u has now the knowledge of its 2-hop topology.

2) *Local topology dissemination*: Periodically, node u disseminates its 2-hop topology knowledge towards all nodes of the network. It first creates a 2-hop topology message, also called a Topology Control (TC) message in OLSR. This message contains the list of nodes in $N(N(u))$. Once created, the TC message is broadcasted towards all nodes in $N(u)$. When receiving a TC message, nodes forward it towards their own 1-hop neighborhood, and so on. In order to avoid infinite loop, a node only forwards a TC message once. A unique sequence number in the TC message header is used for message identification. This process ends when all nodes have forwarded this TC message once. This local topology dissemination algorithm is called Pure Flooding. As a main drawback, this algorithm does not prevent from redundant transmissions, i.e. a transmission is considered to be useless when a node u sends a TC message whereas all nodes in $N(u)$ have already received it before.

We now describe tree based Flooding, Network Coding based approaches and finally Network Coding performed on top of tree based Flooding.

B. Connected Dominated Set based approaches

A Connected Dominated Set (CDS) of a graph G is a set N nodes with the two following properties:

- 1) The sub graph of G induced by D is connected.
- 2) The set D is a dominating set of G , i.e. a node either belongs to D or is adjacent to a node in D .

Connected Dominated Set based approaches consist in selecting nodes to form a CDS and activating forwarding only for this subset. The leaves of the tree do not forward any message. Reducing the number of nodes in the CDS means reducing the number of transmissions required to achieve successful dissemination.

However, finding the CDS with the smallest cardinality is NP-Complete. In the depths of difficulty, building the CDS in ad hoc networks has to be distributed. Many heuristics exist, in this paper we focus on three of them. First we present the one implemented in OLSR -called MPR (Multi Point Relay). Then, we detail two other ones, Dominant Pruning based and Total Dominant Pruning solutions that aim at reducing broadcast Redundancy in ad hoc networks but not in the context of OLSR. The dominant Pruning is one of the first Pruning-based solutions proposed and the Total Dominant Pruning is the most efficient one according to literature.

Connected Dominated Set: MPR heuristic: MPR

stands for Multi Point Relay and is implemented in the last version of OLSR. The heuristic consists, for each node $u \in G$ in proactively selecting the subset of nodes in $N(u)$. Each node acts locally and on a distributive manner. The Multi Point Relay selection process for the node u is detailed in Algorithm 1.

Algorithm 1 MPR heuristic

```

1: procedure MPR(u)
2:   MPR(u) = []
3:   Uncovered(u) = N(N(u))
4:   while ! $\forall v \in N(u) \mid w \in N(v), w \in N(N(u))$  do
5:     MPR(u)  $\leftarrow v$ 
6:     Uncovered(u) = Uncovered(u) - N(v)
7:   end while
8:   while Uncovered(u)  $\neq \emptyset$  do
9:     if  $\max_{v \in N(u)} (|Uncovered(u) \cap N(v)|) > 0$ 
       then
10:      MPR(u)  $\leftarrow v$ 
11:    end if
12:  end while
13:  return MPR(u)
14: end procedure

```

Algorithm 2 MPR Forwarding rules

```

1: procedure MPR(u)
2:   if  $v \in \text{MPR}(u)$  and TCu was not previously Forwarded then
3:     v Broadcasts TCu
4:   end if
5: end procedure

```

Connected Dominated Set: Pruning heuristic:

As the MPR heuristic, Pruning heuristics also use 2-hops information. However, opposing to MPR heuristic where a node u defines a list of forwarding nodes whatever the source node, the Pruning heuristic takes into account the node from which the message is received. Indeed, if the node t has just sent this message then, all nodes in $N(t)$ have received this message too. Therefore, the node u can determine its Relay Nodes list $F(t, u)$ from $B(t, u) = N(u) - N(t)$ in order to Cover nodes in $U(t, u) = N(N(u)) - N(t) - N(u)$ (resp. $U(t, u) = N(N(u)) - N(N(t))$) for the Dominant Pruning (resp. for the Total Dominant Pruning). Let Z be a subset of $U(t, u)$ covered so far, S_i the neighbor set of $v_i \in N(u)$ and K be the set of S_i .

Algorithm 3 Pruning Heuristic

```

1: procedure DOMINANT PRUNING( $v$ )
2:    $F(u) = \{t \in N(u) \mid F(t, u)\}$ 
3:   for  $u \in N(v)$  do
4:      $F(t, u) = \emptyset$ 
5:      $Z = \emptyset$ 
6:      $K \cup S_i$  with  $S_i = N(u_i) \cap U(t, u)$  for  $u_i \in B(t, u)$ 
7:     while  $Z \neq U(t, u)$  do
8:       if  $|S_k \cap U(t, u)| = \max_{S_j \in K} (|S_j \cap U(t, u)|)$  then
9:          $F(t, u) \leftarrow u_k$ 
10:         $Z = Z \cup S_k$ 
11:         $S_j = S_j - S_k \mid S_j \in K$ 
12:      end if
13:    end while
14:  end for
15:  return  $F(v)$ 
16: end procedure

```

When receiving a TC message from u , noted TC_u that have been sent before by t , each node $v \in N(u)$ follows the Forwarding rules detailed in Algorithm 4.

The node v has to know the 2-hops previous sender of the message before re-broadcasting or not the message.

Network Coding Based approaches

Network Coding based approaches aim at reducing number of transmissions by benefiting of the broadcast nature of the wireless medium. In contrary to the flooding tree based solutions, Network Coding techniques do not exclude any nodes from the forwarding activity.

Algorithm 4 Pruning Forwarding

```

rule s
1: procedure MPR(u)
2:   if  $v \in F(t, u)$  and TCu was not previously Forwarded then
3:     v Broadcasts TCu
4:   end if
5: end procedure

```

Deciding which messages are encoded can be done either deterministically or randomly.

1) *Determinist Network Coding*: Determinist Network Coding consists in selecting deterministically a subset of messages to be encoded. In [11], messages are encoded in order to maximize the number of neighbors that will be able to immediately decode it. To do so, nodes need to know the list of messages that have all of their neighbor nodes. This can be achieved by an additional protocol [11].

2) *Random Network Coding*: Random Network Coding consists in combining messages randomly without any knowledge of what have the nodes in the neighborhood.

Crisostomo *et al.* [13] performed a comparison between MPR diffusion and network coding technique. As a main conclusion, the study shows that network coding clearly outperforms MPR in most of the cases.

Hybrid approaches

We refer to hybrid approaches for proposals designed to reduce the number of transmissions required for flooding in wireless ad-hoc networks using network coding on a a Connected Dominating Set. Simple distributed coding scheme which can be applied at each node are proposed in [12] and [11] where the efficiency of network coding is further enhanced by applying multiple point relays (MPR).

1) *MPR-based flooding tree with Determinist Network Coding*: As for simple Determinist Network Coding, a sub- set of messages to be encoded is selected based on neighbor information knowledge. The only difference comes from the fact that this process occurs only on a subset of nodes belonging to a previously defined dominating set. Authors from [11] have used MPR to implement the concept of dominating set coupled with Determinist Network Coding.

2) *MPR-based flooding tree with Random Network Coding*: A subset of messages to be encoded is chosen randomly without any knowledge about neighbor's data. Combining MPR-based flooding and Random Network Coding is performed in [12].

Synthesis and Novel Approaches

Different solutions, flooding tree based, network coding based, or hybrid ones have been investigated. Table I gives an overview of those studied solutions. Columns indicate from left to right flooding algorithms that do not Implement Network Coding ($N_o - N_C$), those using Determinist Network Coding

(D – N C), and those using Random Network Coding (R – N C). Stars (★) indicate solutions that have not yet been investigated but studied within this paper. Citations that appear in the cells of the table help to position work in the literature.

Table I. Classification of diffusion existing METH ODS

| | No NC | D-NC | R-NC |
|-------------------------|-----------|------|------|
| PF | [14] | [11] | [12] |
| MPR-based Flooding Tree | [14],[11] | [11] | [12] |
| Dominant Pruning-based | [15],[16] | ★ | ★ |
| Total Dominant Pruning- | [15],[16] | ★ | ★ |

From this table, we can observe that most studies compared only two possible techniques. Only one study [11] has compared three of them. The aim of this paper is to compare all possible combination within this paper and fill the blank cells, represented by ★: combination of Pruning-based flooding trees and Network Coding techniques (random and deterministic).

Performance Analysis

The solutions that exist in the literature and discussed in this paper have obviously been evaluated by their respective authors. However, these studies were conducted separately and the assessments were made under different conditions and assumptions. Herein we propose to make a synthesis of previous conclusions and complete those works by proposing a global performance gain assessment by using the same simulator developed for this study.

To evaluate the different techniques, both existing and the ones we have proposed in this paper, we have conducted a number of simulations. All dissemination methods mentioned in this article have been evaluated under the same conditions and network parameters: a static ad hoc network with an average degree equal to 4.5. Number of nodes in the topology varies from 20 to 80. Without loss of generality, we consider that PHY/MAC layers ensure perfect collision avoidance for transmissions. Each point on the following curves is the average result of a hundred simulations of the same scenario (number of nodes and diffusion technique).

We evaluate here the required amount of data so that each node’s TC message is received by all nodes in the network and required delay to disseminate data over the entire network.

Dissemination solutions for OLSR

According to Table I, Figure 2 shows the comparison results of six techniques that have been proposed in the

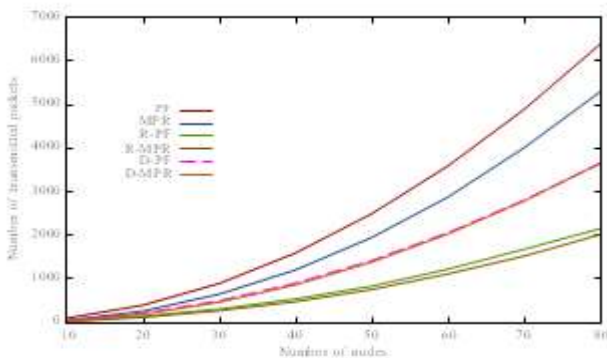

Figure 2. Comparison of existing solutions for OLSR. Observe how random network coding performs better than the deterministic one, whatever the technique it is associated to

Literature: Pure Flooding (PF), Multi-Point Relay (MPR), Random Network Coding combined to Pure Flooding (RNC-PF), Random Network Coding combined to Multi-Point Relay

(RNC-MPR), Deterministic Network Coding combined to Pure Flooding (DNC-PF), and Deterministic Network Coding combined to Multi-Point Relay (DNC-MPR).

The first remark we can make is that PF is the method that generates the most data to disseminate the information throughout the network. This result is logical and expected because PF does not use any optimization technique. The second lesson of this study is that the use of network coding gives better results than the use of a broadcast tree in all cases. We can also see that both methods of network coding give substantially the same results whether or not associated with a broadcast tree. Finally, we note that the use of random network coding gives better results than the deterministic network coding. This last result is surprising because the deterministic network coding is more intelligent and expected to yield better results.

TC message dissemination solutions: comparison

In Figure 3, we compare two methods proposed in the literature for message distribution in a network, but not as part of OLSR. These methods are Partial- and Total- Dominant Pruning tree, respectively noted P-DPT and T- DPT in this figure. We have implemented and compared them with the two techniques available in OLSR: pure flooding (PF) and MPR.

We draw two important lessons from this figure: (i) P-DPT yields results similar to MPR whatever the size of the topology and (ii) T-DPT is the best of the four algorithms used here. Unsurprisingly, PF is the technique that generates the most messages.

Proposed approaches

If we refer to Table 1, we can notice that no work, to the best of our knowledge, combining the techniques of network coding and dominating pruning tree, has been performed in the framework of the diffusion of TC messages in OLSR. In this paper, we not only filled this lack but, in addition, we compared the results obtained by our approach to the best technique proposed for OLSR (Random-MPR) and the best offered in a more generic case (T-DPT).

Figure 4 compares the results of the seven following algorithms: Partial- and Total-Dominant Pruning Tree (respectively noted P-DPT and T-DPT) without combination with network coding, Partial- and Total-Dominant Pruning Tree combined with random network coding, respectively noted R-P-DPT and R-T-DPT, Partial- and Total-Dominant Pruning Tree combined with deterministic network coding, respectively noted D-P-DPT and D-T-DPT, and, finally, MPR technique combined to random network coding, noted R-MPR.

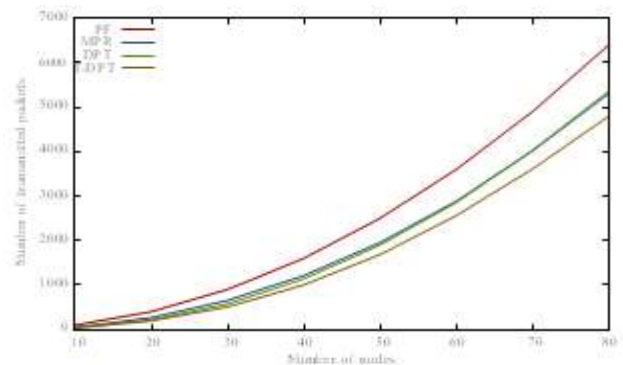

Figure 3. Comparison of OLSR and non-OLSr message diffusion techniques. We can remark that Total-Dominant Pruning Tree gives the best result, while the Partial-Dominant Pruning tree is equivalent to MPR

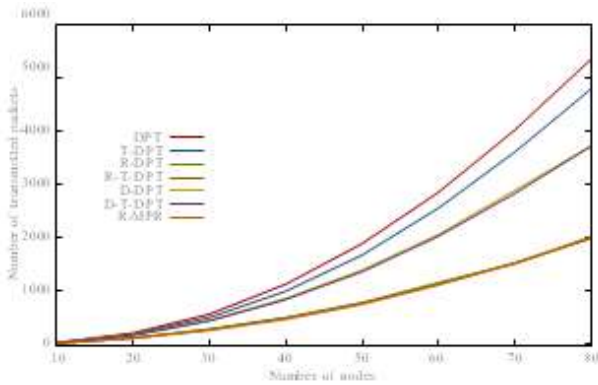

Figure 4. Proposed approaches compared to best existing ones. We observe that (i) random network coding still outperforms deterministic one and that (ii) using network coding reduces the gap between tree-based techniques
Random vs. Deterministic network coding

The first remark we can do here is on the significant interest in the use of network coding. Therefore it is used; the amount of messages in the network has drastically reduced. Then we can notice that T-DPT and P-DPT behave in almost identical ways since they are used with network coding, whether random or deterministic.

When different solutions have been proposed, they have been assessed separately.

As a main result, we show that network coding techniques Generally outperform tree based ones, reducing by up to 50% the number of transmissions. However, we also show to implement and requires less information exchanges to function, achieves a successful dissemination by generating less transmissions than Determinist Network Coding. This is an unexpected result in the sense that Determinist. Network Coding strives to find the best subset of messages to encode in order to satisfy the maximum of neighbors. Once again, this result shows that local optimization does not always lead to global optimal performances.

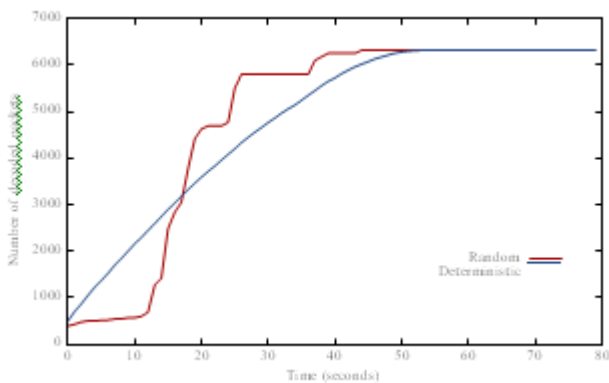

Figure 5. Number of useful packets as a function of time for Random and Deterministic network coding.

We note that using a random network coding on both DPT yields results similar to those of MPR. Finally, we note, again, that the random network coding provides much better results than the deterministic, regardless of the topology and whatever the technique to which it is associated.

As stated in Sections IV-A and IV-C, random network coding provides, contrary to what one might intuitively think, better results than deterministic. Because this result is somewhat non intuitive, we wanted to understand why such behavior. For this, we analyzed the behavior of both methods during a simulation and we have studied the evolution of the number of

useful messages in the network in both cases. The result of this study is presented in Figure 5.

We can observe, on this figure, two different behaviors for the two methods. On the one hand, the number of messages relevant to the deterministic network coding scales linearly as the encoding is done taking into account some neighbor knowledge so they can decode messages when received. On the other hand, the number of messages relevant to the random changes in a more chaotic way, because the encoding of messages is done completely randomly. Thus, as can be seen in the figure, the nodes using random coding receive and store messages that are not useful for a long time before receiving one message which allows to decode a large number of stored messages, which increases the number of useful messages in the network.

Conclusion and future work

In this study we investigate the problem of TC message dissemination in OLSR. The main challenge in this context is to achieve a successful dissemination by minimizing the number of required transmissions. To tackle this issue, two main approaches have been proposed yet. The first consists in selecting a subset of nodes in charge of forwarding TC messages, and a second one consists in using Network Coding techniques to optimize radio resource use. Moreover, that the combination of tree based solutions and network coding improves performance gains in all cases. For the first time, Random Network Coding and Determinist Network Random Network Coding which is less complex the major point of this study is that Random Network Coding presents better results of the most of studied solutions. Moreover, because it does not require any addition in terms of data control, Random Network Coding based solutions seem to be one of the most efficient solutions for information dissemination in wireless ad hoc networks.

As future work, we plan to implement those different Solutions and integrate them into a test bed in order to both prove the concept of our solutions and compare them under real conditions.

References

- [1] J. Broch, D. A. Maltz, D. B. Johnson, Y.-C. Hu, and J. Jetcheva, "A performance comparison of multi-hop wireless ad hoc network routing protocols," in *Mobile Computing and Networking*, pp. 85–97, 1998.
- [2] V. Park and M. Corson, "A Highly Adaptive Distributed Routing Algorithm for Mobile Wireless Networks," in *Proceedings of IEEE INFOCOM 1997*, April 1997.
- [3] C. Perkins, E. M. Royer and S. R. Das, "Ad Hoc On-Demand Distance Vector routing," In IETF Internet Draft, draft-ietf-manet-AODV-13.txt, February 2003.
- [4].C.E.Perkins and E.M. Royer, "Ad hoc on demand distance Vector (AODV) routing,"1999.
- [5] R. Ogier, F. Templin, and M. Lewis, "Topology Dissemination Based on Reverse-Path Forwarding (TBRPF)." RFC, February 2004. IETF RFC-3684.
- [6] T.clausen and P.Jaquet Optimized Link State Routing Protocol, "In IETF Internet Draft,draft-ietf-manet-olsr-11.txt July 2003.
- [7] C.E.Parkins and P.Bhagwat, Highly dynamic destination. Sequenced distance vector routing (dsv) for mobile computers, on "In SIGCOMM '94:proceedings of the conference on communications architecture, protocols and applications,(New York,NY,USA),pp 244,ACM Press,1994

- [8] Z.J.Haas and M.P.Pearlman “Zm a hybrid framework For routing in ad hoc networks,”pp 221-253,2001.
- [9] C.A Santivanez R.Ramanathan and I.Stavrakakis, “Making link-state routing scale for ad hoc networks,” in *MobiHoc’01: Proceedings of the 2nd ACM international symposium on Mobile ad hoc networking & computing*, (New York, NY, USA), pp. 22–32, ACM Press, 2001.
- [10] S. Guha and S. Khuller, “an Approximation algorithm for connected dominating sets,” *Algorithmica*, vol. 20, pp. 374–387, 1996.
- [11] N. Kadi and K. Al agha, “Optimized mpr-based flooding in wireless ad hoc network using network coding,” in *Wireless Days, 2008. WD ’08. 1st IFIP*, pp. 1 –5, nov. 2008.
- [12] N. Kadi and K. Al agha, “Mpr-based flooding with distributed fountain network coding,” in *IEEE WCNC 2010 Wireless Communication and Networking Conference*, pp. 1 – 5, nov.2010.
- [13] S. Crisostomo, J. Barros, and C. Bettstetter, “Flooding the network: Multipoint relays versus network coding,” in *Circuits and Systems for Communications, 2008. ICCSC 2008. 4th IEEE International Conference on*, pp. 119 –124, May 2008.
- [14] A. Qayyum, L. Viennot, and A. Laouiti, “Multipoint relaying for flooding broadcast messages in mobile wireless networks,” in *System Sciences, 2002. HICSS. Proceedings of the 35th Annual Hawaii International Conference on*, pp. 3866 – 3875, Jan. 2002.
- [15] W. Peng and X.-C. Lu, “On the reduction of broadcast redundancy in mobile ad hoc networks,” in *Proceedings of the 1st ACM international symposium on Mobile ad hoc networking & computing, MobiHoc ’00*, (Piscataway, NJ, USA), pp. 129–130, IEEE Press, 2000.
- [16] H. Lim and C. Kim, “Flooding in wireless ad hoc networks,” *Computer Communications*, vol. 24, no. 3-4, pp. 353 – 363, 2001.