

## A Survey on TCP Congestion Control in LTE Network

Sapna Choudhary and Nitin Kumar Shrivastava  
SRIT Jabalpur, India.

## ARTICLE INFO

## Article history:

Received: 17 February 2015;

Received in revised form:  
15 July 2015;

Accepted: 22 July 2015;

## Keywords

TCP,  
Congestion,  
LTE network.

## ABSTRACT

In the Long Term Evolution (LTE) network, buffer overflows often occur in the evolved Node B (eNB) when dealing with the traffic bursts from the wired part due to restricted bandwidth or environmental interferences in the wireless part. In this paper, a survey on approaches is proposed to protect the buffer from overflow by appropriately controlling the advertisement window to enhance the Transmission Control Protocol (TCP) when the buffer becomes congested. The sender will slow down the data sending rate upon the receipt of reduced advertisement window, and hence the buffer overflow will be alleviated. To evaluate the suggested solution, a LTE network model is implemented and validated through extensive numerical experiments. It is demonstrated that the proposed approach can enhance the end to end system performance in terms of network throughput, average packet delay and jitter, as well as packet loss rate.

© 2015 Elixir All rights reserved.

## Introduction

The LTE network is considered as the next generation network technology beyond 3G and one of its key features is the provision of 100 Mbps peak data rate in the downlink (DL) [1], whereas such data rate is still a bottleneck compared with the high-speed wired part. This implies that packets will be buffered and eventually discarded due to buffer overflow in the eNB without efficient congestion control mechanisms.

Obviously, this phenomenon will severely degrade the Service Level Agreement (SLA) of the TCP-based applications. A collection of congestion control mechanisms have been investigated for years in the literature for a variety of networks. In [2], the authors addressed the wireless loss-tolerant congestion control protocol based on dynamic aimed theory. The modeling and configuration of Random Early Detection (RED) algorithm to enhance real-time services was investigated in [3]. Protocol independent congestion control method using mobile relays for ad hoc networks was investigated in [4]. In [5], the authors proposed the application of adaptive virtual queue based RED mechanisms in satellite networks. The Active Queue Management (AQM) with dual virtual queues in the wireless Local Area Network (LAN) was analyzed in [6]. These studies show that the appropriate use of congestion control mechanisms can greatly improve the system performance. In this paper a novel congestion control mechanism is proposed for the LTE network by controlling the TCP advertisement window prior to the buffer overflow in the eNB.

Upon the receipt of the notification, sender will slow down the sending rate to protect the eNB buffer from overflow. To the author's best knowledge, there is few research effort has been made to address the issue of network congestion in the context of eNB through reinforcing the TCP protocol. In addition, the approach presented in this paper can be well applied to other wireless-wired hybrid networks.

## Congestion Control Mechanism

In general, eNB will not interpret the layers above Packet Data Convergence Protocol (PDCP) for the end-to-end data transmission, e.g. the TCP/IP headers of uplink acknowledgements (UL ACKs) and downlink data (DL data), as

illustrated in Fig. 1. TCP sender window (swnd) at the server side is determined by the following formula [7]:

$$swnd = \min\{awnd, cwnd\} \quad (1)$$

where awnd and cwnd are the UL ACK's advertisement window of the User Equipment (UE) and the server TCP congestion window, respectively. When the packet loss is detected by the server, the cwnd will be reduced and the slow start process can be triggered. This intrinsic congestion control behavior of TCP will deteriorate TCP performance [8].

The eNB buffer congestion can be identified by an indication that the number of buffered packets exceeds the predefined congestion threshold, cth, which is determined by

$$cth = b_s * \alpha, 0 < \alpha \leq 1 \quad (2)$$

where  $b_s$  and  $\alpha$  are the size of eNB buffer and a congestion coefficient respectively. Radio Link Control (RLC) in the eNB monitors its buffer space utilization once a packet enters or leaves the queue. If cth is reached, RLC sets the congestion flag. Otherwise the congestion flag is cleared (see Fig. 1 a). After RLC in the UE receives the DL data, it sends UL ACKs to the server (see Fig. 1 b). If the eNB detects the congestion flag, it looks into TCP header and reduces the value of UL ACK awnd with the following formula:

$$awnd = awnd * \beta, 0 < \beta \leq 1 \quad (3)$$

where  $\beta$  is the adjustment coefficient of the ACK awnd (see Fig. 1 c). When TCP in the server receives the reduced awnd, it slows down its sending rate based on the formula (1) (see Fig. 1 d). With this approach, the reinforcement is carried out for the standard TCP protocol, i.e. incorporating awnd control in the eNB (Fig. 1 c) based on the congestion flag configured according to the eNB buffer utilization (Fig. 1 a).

## Congestion Criterion

In the LTE network, buffer overflow in the eNB can occur under either of the following two conditions: (1) the incoming traffic data rate exceeds the bandwidth of the air interface.

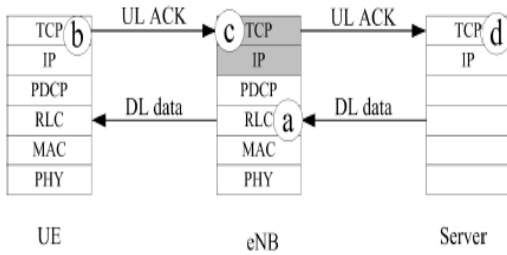

Fig. 1. The proposed congestion control mechanism

The RLC packets will be buffered in the eNB and be dropped when buffer overflows; and (2) various environmental interferences can cause RLC packet loss during transmission in the wireless part of the network. The unsuccessful transmission of RLC packets may result in more incoming RLC packets buffered in the eNB. For both scenarios, the data sending rate needs to be well controlled so as to avoid the eNB's buffer overflow whilst minimize the system performance degradation. In this paper, we consider two buffer congestion scenarios: network congestion and background traffic congestion. The former refers to the case that the total number of buffered packets from all traffic classes reaches  $cth$ ; the latter restricts the view to the background traffic, i.e. the buffered packets of the background traffic reaches  $cth$ .

#### Window Control Mechanism

In practice, the underlying network carries various network services with diverse traffic characteristics and requirements, e.g. Voice over IP (VoIP) applications require low delay and jitter, and generally are not so sensitive to packet loss due to the advances of loss recovery schemes deployed at the receiver, whereas background traffic (refer to LTE traffic Model subsection), such as file transfers, needs reliable data transmission with optimized system performance. Therefore, the proposed window control mechanism is only applied to the background traffic.

Two window control mechanisms are investigated in this paper: overall window control and partial window control. The former means to control all the background traffic flows. Considering this may result in the TCP global synchronization, we also investigate a random approach that a certain number of background traffic flows are selected in a random fashion to be applied with the window control mechanism, i.e. partial window control. The suggested mechanisms will be carried out based on the simple rule that the adjustment coefficient of  $awnd$  should be configured proportionally to the degree of detected eNB buffer congestion, e.g. if it is with a heavy congestion, a significant reduction of  $awnd$  will be carried out. This can improve not only the system's total throughput, but also the system's fairness among the TCP flows [9, 10].

#### Discussion

It is noted that the application of the approach will not require any changes for UE, access gateway (aGW) and server in the LTE network and remains the end to end TCP semantics unchanged. Under the circumstance that no congestion is detected based on the congestion criterion, i.e. the congestion flag is cleared, the eNB will not need to look into the UL ACK during transmission. Otherwise, the congestion flag is set and the eNB has to interpret TCP/IP header which consumes extra CPU and memory resource of the eNB and the interaction between TCP and RLC violates the protocol layer design principle. Also this proposed mechanism can solely work for services in conjunction with TCP protocol (e.g. FTP downloads, web

browsing), i.e. no effects will be obtained for applications carried by other transport protocols.

Another limitation of the solution is that it requires the TCP connection's UL and DL pass the same node, i.e. the same eNB. It is true in most cases except the handover. After UE receives the handover command and before handover is completed, the buffered packets in the source eNB will be delivered to the target eNB [11]. If the  $awnd$  of those packets is reduced, and the buffer in the target eNB doesn't reach  $cth$ , after handover complete, this will lead to the conflict temporarily with the original design, and vice versa. This problem is caused by the last hop change from the source eNB to the target eNB during handover. Therefore, it is suggested to disable the window control mechanism during handover to avoid potential system performance degradation. Further improvements on the proposed solution to support handover are left out for future investigation.

#### Analysis of LTE Network and Traffic Models

To validate the proposed congestion control mechanism, this section presents the modeling approach of LTE network and traffic in details. The models are implemented based on NS-2 (version 2.33) [12] in the Debian operating system and the source code is available at [13]. The separated design of network model and traffic model allows the models can be flexibly reused by other systems as investigated in our previous studies [14, 15].

#### LTE Network Model

The network model can be broken down into three levels when it is implemented in NS-2: node level, agent level and application level, as shown in Fig. 2. At the node level, the following network elements are simulated:

1. a server which provides HTTP, FTP and signaling services
  2. an aGW which provides HTTP cache service
  3. an eNB which provides buffer congestion monitoring, congestion flag setting/clearing and advertisement window control
  4. a set of UEs which support all different traffic applications.
- The agent level aims to simulate a set of network transport protocols, including the TCP, User Datagram Protocol (UDP), Real-time Transport Protocol (RTP) and Real-time Transport Control Protocol (RTCP). Application level at the top simulates network applications, e.g. HTTP, FTP, conversation and Constant Bit Rate (CBR) services.

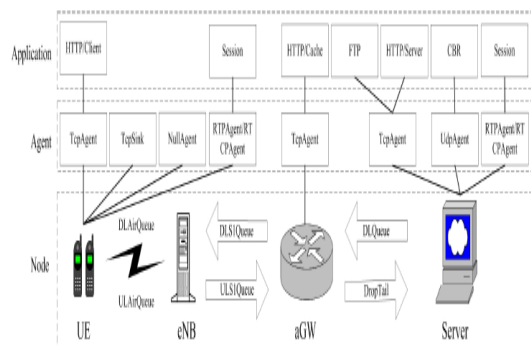

Fig. 2. Network model of the LTE network in NS-2

In the network model, LTEQueue, UL Air Queue, DL Air Queue, UL S1 Queue, DL S1 Queue and DL Queue are implemented to simulate the air interface, S1 interface and Gi DL interface as shown in Fig. 2. The fundamental functions, such as Quality of Service (QoS) and flow control function configurations, can be realized in the parent class LTEQueue and enhancements are implemented in other queues e.g. the interface and link specific features. The main functions which

should be implemented are `enqueue()` and `dequeue()` in those queue classes. Once a packet enters the `LTEQueue`, it will be classified and put into a corresponding sub-queue according to its traffic class. If the QoS feature is not triggered, all the packets will enter the same `DropTail` sub-queue. Otherwise, the packets of conversation, streaming or interactive applications will enter their corresponding `DropTail` sub-queue respectively. The background traffic is carried by TCP and the `REDQueue` sub-queue is applied to achieve improved throughput.

If no QoS requirements are imposed, the packets are scheduled in a first-in-first-out (FIFO) manner. Otherwise, a strict priority based scheduler is used to deal with the packet scheduling with the priority order from high to low as follows:

Conversation traffic, streaming traffic, interactive traffic, and background traffic based on 3GPP. This implies that the lower priority packets can be served only when no higher priority packets are available.

#### LTE Traffic Model

In wired networks, many traffic classes are available which can well characterize different traffic profiles. However, this is not the case in the wireless-wired hybrid networks due to the varied wireless environment. 3GPP only defines four traffic classes: conversational traffic, streaming traffic, interactive traffic and background traffic [16]. Their specific characteristics are presented in Table I. The voice traffic in our daily is one of the most common conversational traffic. In the near future, more and more applications will use this class, such as VoIP, multi-side videoconference. The participants are often the humans, so the end user's experience is critical. If the QoS doesn't reach the required level, it can not be accepted because human can not understand each other. Session/RTP class in NS-2 is used to simulate this traffic. The main implementation is in the file `tcl/rtp/session-rtp.tcl`.

Streaming traffic allows the clients to integrate its data before the whole file is available, so it is used in real time audio and real time video very often. Compared with conversational traffic, it is one way transportation and no requirements on the delay. Because the applications in the endpoint can buffer some data, the jitter requirement is lower. The main implementation is in the file `tools/cbr-traffic.cc`.

When we use HTTP to view the web pages, the traffic class used is interactive traffic. The client sends the requests to the server, it expects the response from the server. In the ordinary life, the proxy server is often used. When the proxy server receives the HTTP requests, it checks whether the cache is hit. If the cache is missed, it forwards the HTTP requests to the server. Otherwise, it continues to check whether the web pages are still valid. If the pages are valid, it responds to the client with cached web pages. Otherwise it downloads the required web pages from the server. The main implementation is in the class `PagePool` in NS-2.

The background traffic has the lowest priority among the four traffic classes. It is insensitive to the delay and jitter more or less. However, it still requires the data is transported reliable from end to end, like the interactive traffic. Thus, the data is transparent to the above applications. The transport layer protocol used is typical the TCP protocol which is implemented in `tcl/lib/ns-source.tcl`.

#### Conclusions

In this paper we survey a congestion control mechanism to avoid buffer overflow at eNB through controlling the advertisement window of TCP in the LTE network. The mechanism is implemented and verified through numerical simulation experiments. The result demonstrates its effectiveness

on system performance improvement in terms of network throughput, average packet delay and jitter, as well as the packet loss rate in the LTE network. Due to the fact that the operation of the mechanism is only applied for the background traffic, the performance of higher priority traffic will not be sacrificed. In respect to the future work, further improvements are being exploited to make the mechanism support handover in the LTE network. Another aspect is that currently congestion coefficient and adjustment coefficient of the mechanism are configured with fixed values. Adaptive configurations according to the LTE traffic dynamics would further enhance the performance of the solution.

#### References

- [1] 3GPP TR 25.913 V9.0.0, "Requirements for Evolved UTRA (E-UTRA) and Evolved UTRAN (E-UTRAN) (Release 9)," Sophia Antipolis Valbonne, France: technical specification group radio access network, the 3rd Generation Partnership Project, Dec. 2009.
- [2] C. H. Nishiyama, N. Ansari and N. Kato, "Wireless loss-tolerant congestion control protocol based on dynamic aimed theory," *IEEE Wireless Communications*, vol. 17, no. 2, pp. 7-14, April 2010.
- [3] Q. Yang and J. Pitts, "Scalable voice over internet protocol service-level agreement guarantees in converged transmission control protocol/internet protocol networks," *IET Communications*, vol. 10, no.8, pp.1026-1035, 2010.
- [4] B. N. Yuvaraju and N. N. Chiplunkar, "PICCO: Protocol Independent Congestion Control Method Using Mobile Relays for Ad-Hoc Networks," in *Proc. ICCNT*, pp.93-97, April 2010.
- [5] D. J. Byun, and J. S. Baras, "Adaptive virtual queue random early detection in satellite networks," *IEEE Wireless Telecomms Symp.*, pp. 1-9, April 2007.
- [6] Q. Y. Xia, X. Jin, and M. Hamdi, "AQM with dual virtual PI queues for TCP uplink/downlink fairness in infrastructure WLANs," in *Proc. IEEE Wireless Comms. & Netw. Conf.*, pp. 2137-2142, June 2007.
- [7] IETF RFC 793, "Transmission Control Protocol," Network Working Group, Internet Engineering Task Force, September 1981.
- [8] K. Pentikousis, "TCP in wired-cum-wireless environments," *IEEE Communications & Surveys Tutorials*, vol. 3, no. 4, pp. 2-14, 2000.
- [9] S. Pilosof, R. Ramjee, D. Raz, Y. Shavitt and P. Shinha, "Understanding TCP fairness over wireless LAN," *Proc. IEEE INFOCOM 2003*, vol.2, pp.863-872, March 2003.
- [10] F. Keceli, I. Inan and E. Ayanoglu, "TCP ACK congestion control and filtering for fairness provision in the uplink of IEEE 802.11 infrastructure basic service set," *Proc. IEEE International Conference on Communications*, pp.4512-4517, June 2007.
- [11] 3GPP TR 25.813 V7.1.0, "Evolved Universal Terrestrial Radio Access (E-UTRA) and Evolved Universal Terrestrial Radio Access Network (EUTRAN); Radio interface protocol aspects (Release 7)," September 2006.
- [12] NS-2 on-line manual and documents, VINT project. Available from <http://nslam.isi.edu/nslam/index.php/MainPage>.
- [13] Source code of LTE network model and traffic model in NS-2. Available from <http://code.google.com/p/lte-model/>.
- [14] Q. L. Qiu, J. Chen, L. D. Ping, Q. F. Zhang and X. Z. Pan, "LTE/SAE Model and its Implementation in NS-2," In *Proc. MSN'09*, pp. 299-303, Dec. 2009.

- [15] Q. L. Qiu, D. M. Zhang and J. Ma, "GPRS network simulation model in NS-2," In Proc. APCC&MDMC, vol. 2, pp. 700-704, Aug. 2004.
- [16] 3GPP TS 23.107 V9.1.0, "Quality of Service (QoS) concept and architecture (Release 9)," Sophia Antipolis Valbonne,

France: technical specification group services and system aspects, the 3rd Generation Partnership Project, June 2010.

- [17] IETF RFC 2616, "Request for comments: 2616, Hypertext Transfer Protocol - HTTP/1.1," Network Working Group, Internet Engineering Task Force, June 1999.