



On Quantified Analysis and Evaluation for Development Reading Brain Performance using Neural Networks' Modeling

Hassan M. H. Mustafa¹, Alshahrani Mohammed², Mohamed Abdulrahman³, Nada M. Al-shenawy⁴, Shahinaz Mahmoud⁵ and Ayoub Al-Hamadi⁶

¹Computer Engineering Department, Faculty of Engineering, Al-Baha University, Al-Baha, KSA.

²Computer science school Wuhan university, China.

³Electrical Engineering Department, Faculty of Engineering, Al-Baha University, Al-Baha, KSA.

⁴Computer and Control Department, Faculty of Engineering, Tanta University, Egypt.

⁵Instructional & Information Technology Educational Technology Department, Women College, Ain Shams University, Cairo, Egypt.

⁶Institute for Electronics, Signal Processing and Communications (IESK) Otto-von-Guericke-University Magdeburg, Germany.

ARTICLE INFO

Article history:

Received: 5 September 2015;

Received in revised form:

24 September 2015;

Accepted: 29 September 2015;

Keywords

Interdisciplinary Research Discipline,
Reading Brain,
Artificial Neural Networks' Modeling,
Hebian Learning Model.

ABSTRACT

Neurological researchers have recently revealed their findings about increasingly common and sophisticated role of Artificial neural networks (ANN^s). That applied for systematic realistic modeling of interdisciplinary discipline incorporating neuroscience, education, and cognitive sciences. Accordingly, ANN Models vary in relation to the nature of assigned brain functioning to be modeled. For example, as human learning takes place according to received stimuli that is simulated realistically through self-organization paradigm by artificial neural networks modeling. This piece of research adopts the conceptual approach of (ANN) models inspired by functioning of highly specialized biological neurons in reading brain based on the organization the brain's structures/substructures. Additionally, in accordance with the prevailing concept of individual intrinsic characterized properties of highly specialized neurons, presented models closely correspond to performance of these neurons for developing reading brain in a significant way. More specifically, introduced models concerned with their important role played in carrying out cognitive brain function' outcomes. The cognitive goal for reading brain is to translate that orthographic word-form into a spoken word (phonological word-form). In this context herein, the presented work illustrates via ANN simulation results: How ensembles of highly specialized neurons could be dynamically involved in performing the cognitive function of developing reading brain.

© 2015 Elixir All rights reserved.

Introduction

The ensembles of highly specialized neurons (neural networks) in human play the dominant dynamical role in the functioning for developing of reading brain [3]. In accordance with referring to contemporary neuroscience evaluation, there are possibly great implications for learners, tutors, and educationalists. Modeling of the popular and sophisticated type of complex system named "Artificial Neural Network"(ANN) has been adopted. Where collection of artificial neurons (nodes) are linked up in various ways, and the network then processes "synapses" according to a distribution of weights for the connections between the neurons and transfer functions for each individual neuron [2]. The synaptic connectivity patterns among artificial neurons has implication on learning ability [3], and also on the human learning creativity [4]. More specifically, modeling of complex neural network may be considered as a series of highly interconnected nodes (artificial neurons) contributing spoken words for reading brain. Interestingly, it is noticeable that adopted neural networks' models correspond closely to biological neuronal systems functionally as well as structurally[5]

In nature, the working memory components contribute to development of a functional system for a reading brain.

Accordingly, reading process in human brain performed as transferring of written (seen) word-form into pronounced (spoken) word-form. This reading brain process viewed to be performed by brain moment our eyes fall on depicted written word-form, a complex set of physical, neurological, and cognitive processes is originated. That enabling reading brain (via highly specialized neurons) to carry out conversion coding process of a written (orthographic word-form) into a spoken word (phonological word-form).Accordingly, number of highly specialized neurons at corresponding visual brain area contribute to the perceived sight (seen) signal. The increase of this number proved to be in direct proportionality with the correctness of identified depicted / printed images. These images represent the orthographic word-form has to be transferred subsequently into a spoken word (phonological word-form) during reading process. So, the reader may also code morphological structure (base word plus prefix and/or suffix/es) of both the orthographic and phonological word-form [1]. Furthermore, individual intrinsic characteristics of such highly specialized neurons (in visual brain area) influence directly on the correctness of identified images associated with orthographic word-form [6].

The extremely composite biological structure of human brain results in everyday behavioral brain functions. At the educational field, it is observable that learning process performed by human brain is affected with the simple neuronal

performance mechanism [7]. Accordingly, in general sense, the human ability to speak (read) English language is motivated by associative features of human brain. That association considered between two stimulating signals (heard voice and seen written words) via brain receptor neurons. In brief, artificial neural networks were originally conceived of in relation to how systems according to the stimuli they receive [8]. Moreover a recently published research work revealed that using some pauses while talking, may enhance the teaching methodology of children how to read English language [9][10]. Recently, a related research work has been published. That addressed the issue of how ensembles of highly specialized neurons could be dynamically involved in performing the cognitive function of recognizing words' vocabulary during early infancy development of human reading brain [11]. Finally, it is worthy to note that presented study motivated by some recently other published interdisciplinary work dealing with the intrinsic properties of neurons associated with learning creativity [12] and brain-based learning[13]. The rest of this paper is composed of four sections including the introductory one organized as follows. At section 2, principal of interactive learning presented in two subsections. Simulation results introduced section 3. Finally, the last fourth section presents some conclusions and suggested future work.

Reading brain modeling

Basic learning/teaching ANN model

A generalized block diagram for realistic simulation of interactive learning /teaching process is illustrated at Figure 1. Futhermore, a suggested learning/teaching ineractive reading perocess modeled as given Figure 2. Referring to Figure 1, it considerst wo diverse paradigms. Namely: classical supervised by teacher (face to face tutoring) and other unsupervised self-organized. Both are referred respectively as field dependant and independant cognitive styles as illustrated at [14]. Accordingly, the first paradigm proceeds interactively via bidirectional communication process between teacher and his learner (s).However, the other paradigm performs self-organized learning /teaching process (autonomously).

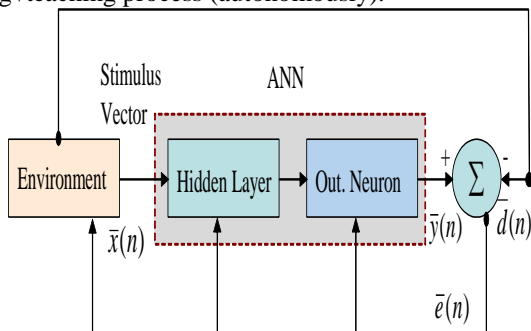

Fig 1. Basic learning/teaching ANN block diagram model for simulating realistic of learning paradigms (adapted from [15])

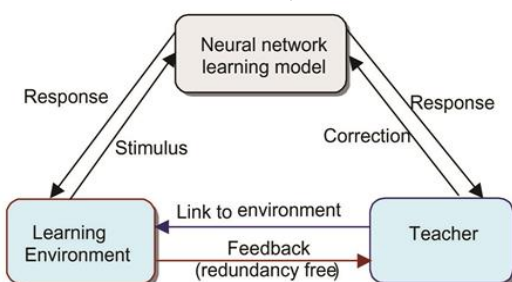

Fig 2. Illustrates a view for interactive brain based learning/teaching ineractive reading perocess (adapted from[20])

Mathematical formulation of basic learning/teaching ANN block diagram is given as follows. After considering any error observed at arbitrary time instant (n) during proceeding of learning process to be given generally by vector $\bar{e}(n)$:

$$\bar{e}(n) = \bar{y}(n) - \bar{d}(n) \tag{1}$$

where $\bar{e}(n)$ is the error correcting signal which is controlling adaptively the learning process, and $\bar{y}(n)$ is the output signal of the model. $\bar{d}(n)$ is the desired numeric value(s). Moreover, the following four equations are deduced:

$$V_k(n) = X_j(n)W_{kj}^T(n) \tag{2}$$

$$Y_k(n) = \phi(V_k(n)) = (1 - e^{-\lambda V_k(n)}) / (1 + e^{-\lambda V_k(n)}) \tag{3}$$

$$e_k(n) = |d_k(n) - y_k(n)| \tag{4}$$

$$W_{kj}(n+1) = W_{kj}(n) + \Delta W_{kj}(n) \tag{5}$$

where X is input vector and W is the weight vector. ϕ is the activation function. Y is the output. e_k is the error value and d_k is the desired output. Note that $\Delta W_{kj}(n)$ is the dynamical change of weight vector value. Above four equations are commonly applied for both learning paradigms: supervised (interactive learning with a tutor), and unsupervised (learning though student's self-study). The dynamical changes of weight vector value specifically for supervised phase is given by:

$$\Delta W_{kj}(n) = \eta e_k(n) X_j(n) \tag{6}$$

Where η is the learning rate value during the learning process for both learning paradigms. However, for unsupervised paradigm, dynamical change of weight vector value is given by:

$$\Delta W_{kj}(n) = \eta Y_k(n) X_j(n) \tag{7}$$

Noting that error value $e_k(n)$ in (6) is substituted by $y_k(n)$ at any arbitrary time instant (n) during the learning process.

In the context of biological sciences , response signals' strength are dependent on the transfer properties of the output motor neuron stimulating salivation gland. The represented structural simplified model given at Fig 3 considers the original Hebbian learning rule.

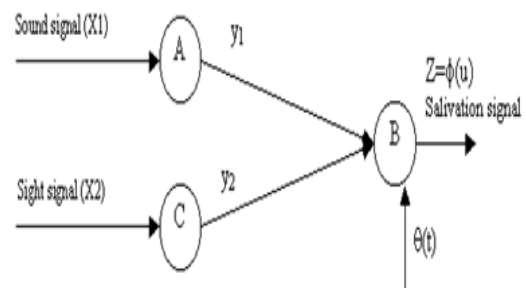

Fig 3. The structure of simplified Hebbian model form (adapted from[16])

Reading process model

Referring to the two figures (Fig.4&Fig.5) shown in below, suggested models obeys that concept as the two inputs I_1, I_2 represent sound (heard) stimulus which simulates *phonological word-form* and visual (sight) stimulus which simulates *orthographic word-form* respectively. The outputs O_1, O_2 are representing pronouncing and image recognition processes respectively. In order to justify the superiority and optimality of phonic approach over other teaching to read methods, an

elaborated mathematical representation is introduced for two different neuro-biologically based models. Any of models needs to learn how to behave (to perform reading tasks). Somebody has to teach (for supervised learning) - not in our case – or rather for our learning process is carried out on the base of former knowledge of environment problem (learning without a teacher). The model obeys the original Hebbian learning rule. The reading process is simulated at that model in analogues manner to the previous simulation for Pavlovian conditioning learning. The input stimuli to the model are considered as either conditioned or unconditioned stimuli. Visual and audible signals are considered interchangeably for training the model to get desired responses at the output of the model. Moreover the model obeys more elaborate mathematical analysis for Pavlovian learning process [17]. Also, the model is modified following general Hebbian algorithm (GHA) and correlation matrix memory[18][19]. The adopted model is designed basically following after simulation of the previously measured performance of classical conditioning experiments. The model design concept is presented after the mathematical transformation of some biological hypotheses. In fact, these hypotheses are derived according to cognitive/ behavioral tasks observed during the experimental learning process .

The structure of the model following the original Hebbian learning rule in its simplified form (single neuronal output) is given in Fig.3, where A and C represent two sensory neurons (receptors)/ areas and B is nervous subsystem developing output response. The below simple structure at

Fig. 5 drives an output response reading function (pronouncing) that is represented as O_1 . However the other output response represented as O_2 is obtained when input sound is considered as conditioned stimulus. Hence visual recognition as condition response of the heard letter/ word is obtained as output O_2 . In accordance with biology, the strength of response signal is dependent upon the transfer properties of the output motor neuron stimulating salivation gland. The structure of the model following the original Hebbian learning rule in its simplified form is given in Fig.3. That figure represents the classical conditioning learning process where each of lettered circles A, B, and C represents a neuron cell body. The line connecting cell bodies are the axons that terminate synaptic junctions. The signals released out from sound and sight sensor neurons A and C are represented by y_1 and y_2 respectively.

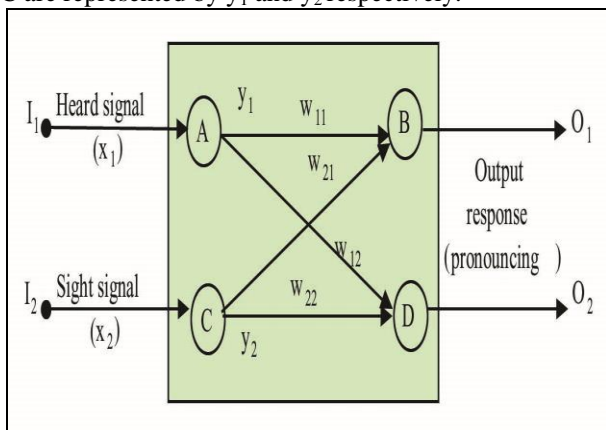

Fig 4. Generalized reading model which presented as pronouncing of some word (s) considering input stimuli and output responses

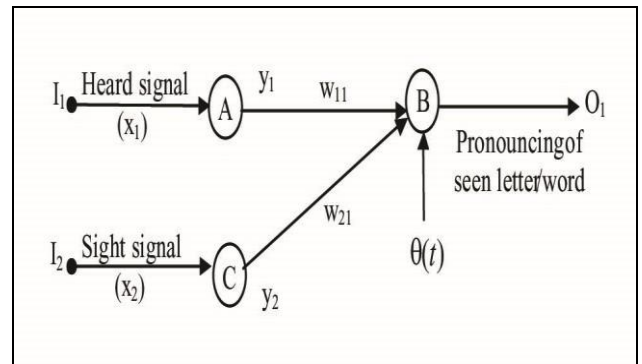

Fig 5. The structure of the first model where reading process is expressed by conditioned response for seen letter/ word (adapted from [17])

Simulation results

Interestingly, obtained simulation results herein are observed to be in agreement with obtained results after analytical approach adopted by recently published work at[11]. Therein, depicted graphical results observed to agree with that presented herein at Figure 6.

$$\lambda = 0.5 \quad \& \quad \lambda = 1 \quad \& \quad \lambda = 2$$

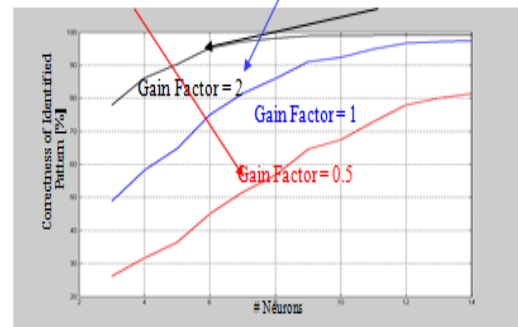

Fig 6. Illustrate students' learning achievement for different gain factors and intrinsically various number of highly specialized reading neurons which measured for costant learning rate value = 0.3.

Conclusions and future work

This study of presents how highly specialized neurons could be dynamically simulated realistically. It shows that flock of neurons interacts together among the flock’s agents to perform a specific common role (Reading function) via visual and auditory brain areas. The following three remarks are concluded:

- At Figure 7, the increasing number of highly specified neurons (contributing to reading process) is corresponding analogously to personal individual differences of students.
- The gain factor parameter of ANN represents the commonly individual intrinsic differences among flock of highly specified neurons as given by λ in equation (3) at the sub-section(2.1)
- This work motivated by associative memorization based upon pavlovian experimental work as shown at Fig.3. in addition to adopting GENERALIZED HEBBIAN ALGORITHM (GHA). However for future extension of this work it is recommended to adopt Hopfield neural network for associative memorization between seen word (orthographic word-form) and a spoken word (phonological word-form).

References

[1] The Developing of Reading Brain <http://www.education.com/reference/article/brain-and-learning/#B>.
 [2]. Hardman, M. "Complex Neural Networks - A Useful Model of Human Learning ", Paper presented at the British

Educational Research Association (BERA) conference, September 2010.

http://www.academia.edu/336751/Complex_Neural_Networks_-_A_Useful_Model_of_Human_Learning

[3] Ghonaimy M.A., Al – Bassiouni, A.M. and Hassan H.M "Learning Ability in Neural Network Model" Second International Conference on Artificial Intelligence Applications, Cairo, Egypt, Jan. 22-24, 1994, PP-400-413.

[4]H.M.Hassan, "On Analysis of Quantifying Learning Creativity Phenomenon Considering Brain Synaptic Plasticity", published at WSSEC08 conference held on 18-22 August 2008, Derry, Northern Ireland.

[5]Caudil, M. "The view from now", AI Export Magazine, June. (1992), pp.24-31.

[6] A. Borzenko "Neuron mechanism of human languages" Published in IJCNN'09 Proceedings of the 2009 international joint conference on Neural Networks IEEE Press Piscataway, NJ, USA ©2009 ISBN: 978-1-4244-3549-4.

[7]Cilliers, P. (1998) Complexity and postmodernism: understanding complex systems, London: Routledge. Feeman, J. (1999) How Brains Make Up Their Minds. London: Weidenfeld & Nicolson

[8] M.Fukaya, et.al"Two level Neural Networks: Learning by Interaction with Environment", 1st ICNN, San Diego, (1987).

[9]<http://www.scientificamerican.com/podcast/episode.cfm?id=our-uhs-and-ums-may-help-children-1-11-04-17>

[10]Zhang Y, Koerner T, Miller S, Grice-Patil Z, Svec A, Akbari D, Tusler L, Carney E. "Neural coding of formant-exaggerated speech in the infant brain" Published at .Dev Sci. 2011 May;14(3):566-81. doi: 10.1111/j.1467-7687.2010.01004.x. Epub 2010 Nov 23.

[11] Mustafa, H.M." Quantified Analysis And Evaluation Of Highly Specialized Neurons' Role In Developing Reading Brain (Neural Networks Approach)" Published at EDULEARN13, the 5th annual International Conference on Education and New Learning Technologies which held in Barcelona (Spain), on the 1st, 2nd and 3rd of July, 2013.

[12]Mustafa, H.M, et. al. "On Quantifying of Learning Creativity through Simulation and Modeling of Swarm Intelligence and Neural Networks" published at IEEE EDUCON 2011, on Education Engineering – Learning Environments and Ecosystems in Engineering Education, to be held on April 4 - 6, 2011, Amman, Jordan.

[13] H.M. Mustafa "On Performance Evaluation of Brain Based Learning Processes Using Neural Networks" Published at the Seventeenth IEEE Symposium on Computers and Communication (ISCC '12) July 1 - 4, 2012, Cappadocia, Turkey.

[14] Mustafa, et. al. "On Assessment of Brain Function Adaptability in Open Learning Systems Using Neural Networks Modeling (Cognitive Styles Approach)" published at ICCIT-2011, held on Mar 29, 2011 - Mar 31, 2011, Aqaba, Jordan.

[15] "On Optimality of Teaching Quality for a Mathematical Topic Using Neural Networks (With a Case Study) ". Published at proceeding of IEEE Global Engineering Education Conference (IEEE EDUCON 2013), Berlin, Germany, March 13-15, 2013. Pages: 422-430. Available online at: http://ieeexplore.ieee.org/xpl/login.jsp?tp=&arnumber=6530140&url=http%3A%2F%2Fieeexplore.ieee.org%2Fxppls%2Fabs_all.jsp%3Farnumber%3D6530140

[16] H.M.Hassan, "A Comparative Analogy between Swarm Smarts Intelligence and Neural Network Systems", published at WSSEC08 conference held on 18-22 August 2008, Derry, Northern Ireland.

[17]Mustafa, H.M, Al-Hamadi, A., Al-Saleem, S. Towards Evaluation of Phonics Method for Teaching of Reading Using Artificial Neural Networks (A Cognitive Modeling Approach). Published at IEEE Symposium on Signal Processing and Information Technology Seventh Symposium, Cairo 2007.

[18]Hebb, D.O. "The organization of Behavior", A Neuropsychological Theory, New York, Wiley, 1949.

[19]Haykin S., Neural Networks, Englewood Cliffs, NJ: Prentice-Hall, 1999, pp 50-60.