

IR based Traffic density control

C.Vamsivarshika

SPMVV 1, Near West Railway Station, Tirupati , India.

ARTICLE INFO

Article history:

Received: 18 January 2017;

Received in revised form:
3 May 2017;

Accepted: 15 May 2017;

Keywords

Microcontrollers,
IR Sensors.

ABSTRACT

The main aim is to reduce traffic congestion and unwanted long time delay during the traffic light switch over when the traffic is low. It is placed near the junctions where the traffic signals are placed. It keeps a track of the vehicles in each road and adjusts according to time. When the density increases it can be controlled using IR technology and 89C51 microcontroller. Purpose of the 89C51 having efficient architecture which used in low end security systems and IR is widely adapted technology for communication.

© 2017 Elixir All rights reserved.

Introduction

Nowadays traffic are very high near the signals to overcome long time IR sensors are used. These IR sensors are placed near the junction it senses the heavy traffic in that signals switches to green to make move on that heavy traffic vehicles. By implementing this the wastage of time can be reduced on the roads.

Procedure

Start: Initially the signal are started by giving power supply. In this state to check all the signals are ON state.

Check for signals: Density is calculated by using IR circuit. Depending on the number of vehicles that cut the light travelling from receiver to transmitter of the IR circuit the count of the vehicles are registered in the microcontroller.

Check for the density of the roads: In this state the microcontroller decides which road should be given as highest priority. This is based on the density of the road and also depends on the speed at which IR circuit registers the count.

Check for the priority of roads are to be opened: Time delays have already been set for certain specific counts in microcontroller. As soon as the microcontroller receives the counts from IR circuit will immediately detect the density of each road and accordingly allot the time delays for which each signal will show green colour. The higher the traffic the longer the delay.

Choose appropriate based delays: In the final step, the microcontroller makes sure that the lowest density road is also opened and that the delay of the green light for that particular signal also comes to an end. Once all the roads are opened in a sequence, then the microcontroller again goes back to the second step where it checks for the density of traffic in each road. The whole process is repeated like a cycle. The main point that is to be noted regarding this process is that, whenever a particular road has no traffic, correspondingly, the yellow light in the traffic signal will glow.

Parameters considered

Density of roads

Density of roads is classified as:

- Minimum
- Maximum Priority of roads

Priority of roads

- If two or more roads of equal high priority any one road is opened.
- If all roads are having no traffic, normal count appears.
- No road is allowed to be closed continuously for more than maximum duration
- Without considering the density.

Delay of roads

Delay of roads the delay of each road is chosen according to the density

- Minimum-40000 microseconds
- Maximum-50000microseconds.

Functioning Of Microcontroller In Heavy Traffic

Designing of this system is possible when you select the specific controller to suite. 89C51 controller is selected. With the help of 89C51 controller traffic control system can be implemented successfully with the help IR technology. To the controller we connected IR transmitter and receiver circuit. Instead of IR transmitter and receiver photo diode and photo transmitters are used. Here we are using four IR pairs for each side. Whenever vehicles reach the junction on each side, then IR detects the vehicle by sending signal to controller and the controller will counts the count of vehicles and calculate the maximum count from them and give the path to side which has maximum count by glowing green LED and other LED and other three sides red LED shall be glow.

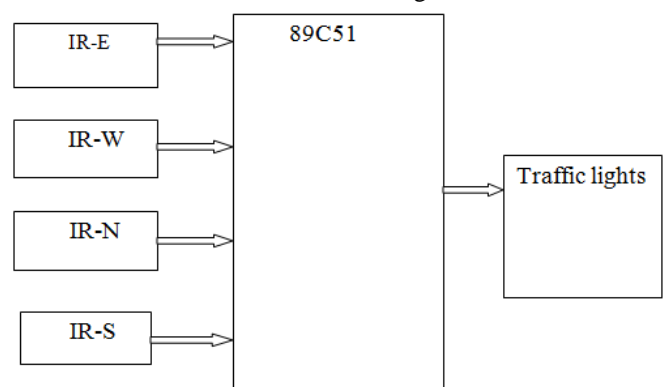

Figure . Overall Block diagram.

Final Results

- Fuel is saved to about 70% compared to normal timer based traffic control.
- Traffic can be cleared without any irregularities.
- Time can be shared evenly for all intersections and
- Effective time management.

Future Scope

To reduce the congestion and unwanted time delay in traffic, an advanced system is required. One such advanced technology is automatic signaling using IR sensors. The sensors help in Keeping Count of vehicles entering roads and subsequently allot time delay thereby giving accurate priority to each road for the time being.

Bibliography

[1] [Ben-Akiva et al., 2003] Ben-Akiva, M., Cuneo, D., Hasan, M., Jha, M., and Yang, Q. (2003). Evaluation of freeway control using a microscopic simulation laboratory Transportation research Part C: emerging technologies, 11-1:29-50.

[2] [Broucke and Varaiya, 1996] Broucke, M. and Varaiya, P. (1996). A theory of traffic flow in automated highway systems. Transportation research Part C: emerging technologies, V4:181-210. [Choi et al., 2002]

[3] Choi, W., Yoon, H., Kim, K., Chung, I., and Lee, S. (2002). A traffic light controlling FLC considering the traffic congestion. In Pal, N. and Sugeno, M., editors, Advances in Soft Computing - AFSS 2002, International Conference on Fuzzy Systems, pages 69-75.

[4] [Findler and Stapp, 1992] Findler, N. and Stapp, J. (1992). A distributed approach to Optimized control of street traffic signals. Journal of Transportation Engineering, 118- 1:99-110.

[5] [Horowitz and Varaiya, 2000] Horowitz, R. and Varaiya, P. (2000). Control design of an automated highway system. In Proc. IEEE, vol. 88.